

OWNER'S MANUAL

BG ZERO TASK SUPPORT VEHICLE



ACTUAL PRODUCT MAY NOT APPEAR EXACTLY AS SHOWN



WARNING

Do not operate or service this product unless you have read and fully understand the entire contents of this manual. Failure to do so may result in property damage, bodily injury or death.

BLUE GIANT[®]

ISSUE DATE: MARCH 12, 2024 REV. 1.0 (PART # 038-810E)

WARNING

Do not operate this vehicle unless you have been authorized and trained to do so, and have read all warnings and instructions in Operator's Manual and on this vehicle. Read, understand and comply with the information on the vehicle's nameplate at all times.

Do not operate this vehicle until you have performed the daily operation's check list. Verify and inspect tires, horn, battery, controller, lift and hydraulic systems, brakes, steering mechanism and guards. Verify that all emergency controls, personal protection and safety devices are in place and functioning correctly and ensure the vehicle is free of fluid leaks and has no loose or missing parts. Report any problems to the designated authority and do not use the vehicle until they are corrected by a qualified mechanic.

This vehicle must not be modified without the manufacturer's consent. Components critical to the vehicles stability such as batteries shall not be replaced with lighter weight components.

Operate vehicle only from designated platform operating position. Use this vehicle indoors on level surfaces only. Never operate on ramps and slopes or uneven floors. This vehicle is not for use on mezzanines or balcony areas. Before operating, inspect the floor area it will be used on and be certain it will support the vehicle at full capacity and lift height. Identify and avoid holes, drop-offs, bumps and obstructions.

Before and during all vehicle operations ensure that adequate clearance is maintained from overhead

obstructions and energized electrical conductors and parts.

Before elevating platform be sure access gates are in position. Keep feet on platform floor at all times while using vehicle, never climb onto access gates or platform shelf. Do not use ladders, planks or other devices to achieve additional height on platform.

When transferring loads to platform or platform shelf, do not exceed capacity ratings on vehicle nameplate. Ensure loads are centered and do not contact any obstructions in the vehicle's vicinity. Do not stabilize the platform by contact with adjacent objects such as racks or shelving. Do not use the platform as a crane.

Take care to prevent electrical cords, hoses or other equipment from entangling in platform. Ensure area surrounding the vehicle is free of personnel and equipment before lowering platform.

Maintain a clear view of the ground while travelling and a safe distance from obstacles in the vehicle or platform's path. Ensure personnel in the vicinity are aware of the vehicle's movement. Travel at a safe speed for the conditions the vehicle is operating in.

Observe applicable traffic regulations. Yield right of way to pedestrians. Slow down and sound horn at cross aisles and wherever vision is obstructed. Avoid hazardous locations.

Enter and exit platform only through open access gates and with the platform fully lowered and vehicle stopped. When leaving vehicle unattended, remove key to prevent unauthorized use.

TABLE OF CONTENTS

Section	Page	Section	Page
1 DESCRIPTION	1-1	6 TRANSMISSION, DRIVE WHEEL, LOAD WHEEL AND CASTERS	6-1
1-1 INTRODUCTION	1-1	6-1 TRANSMISSION AND DRIVE MOTOR	6-1
1-2 GENERAL DESCRIPTION	1-1	6-2 LOAD WHEEL	6-2
1-3 DATA PLATE AND WARNING DECAL	1-3	6-2.1 Removal	6-2
1-4 INSTALLATION / WARRANTY CHECK LIST	1-3	6-2.2 Installation	6-2
2 PLANNED MAINTENANCE	2-1	6-3 DRIVE WHEEL	6-2
2-1 GENERAL	2-1	6-4 CASTER	6-2
2-2 MONTHLY AND QUARTERLY CHECKS	2-1	7 ELEVATION SYSTEM SERVICING	7-1
2-3 FREQUENT INSPECTIONS	2-1	7-1 GENERAL	7-1
2-4 ANNUAL INSPECTIONS	2-1	7-2 LIFT CHAIN LENGTH ADJUSTMENT	7-1
2-5 BATTERY CARE	2-1	7-3 LIFT CHAIN WEAR INSPECTION	7-2
2-5.1 General	2-1	7-4 LIFT CHAIN REPLACEMENT	7-2
2-5.2 Safety Rules	2-2	7-4.1 Three Stage Mast	7-2
2-5.3 Maintenance Personnel	2-2	7-4.1.1 Mast Lifting Chain	7-2
2-5.4 Battery Care and Charging	2-2	7-5 LIFT CYLINDERS	7-2
2-5.5 Battery Cleaning	2-2	8 HYDRAULIC SYSTEM SERVICING	8-1
2-5.6 Maintenance Free Batteries	2-2	8-1 LINES AND FITTINGS	8-1
2-6 CHARGING BATTERIES	2-3	8-2 HYDRAULIC PUMP, MOTOR, AND RESERVOIR ASSEMBLY	8-1
2-7 REPLACING BATTERIES	2-3	8-2.1 Removal	8-1
2-7.1 Battery disposal	2-3	8-2.2 Installation	8-3
2-8 LUBRICATION	2-4	8-2.3 Disassembly and Reassembly	8-3
2-9 LIFT CHAIN MAINTENANCE	2-4	8-3 LIFT CYLINDER - MAIN	8-3
3 TROUBLESHOOTING	3-1	8-3.1 Removal	8-3
3-1 GENERAL	3-1	8-3.2 Repair	8-4
3-2 CONTROLLER TROUBLESHOOTING	3-4	8-3.3 Installation	8-4
3-2.1 Zapi Handset	3-4	8-4 LIFT CYLINDER - TRAY	8-4
3-2.2 Fault Detection	3-4	8-4.1 Removal	8-4
3-2.2.1 General	3-4	8-4.2 Repair	8-4
3-2.2.2 Logbook Access	3-4	8-4.3 Installation	8-4
3-2.3 Testing Vehicle Operation	3-4	9 ELECTRICAL COMPONENTS	9-1
3-2.4 Factory Settings	3-5	9-1 ELECTRICAL CONTROL PANEL	9-1
4 STEERING SYSTEM	4-1	9-1.1 Maintenance	9-1
4-1 CONTROL ARM	4-1	9-1.2 Cleaning	9-1
4-1.1 Steering Control Removal	4-1	9-1.3 Panel Removal	9-1
4-1.2 Steering Control Installation	4-2	9-1.4 Panel disassembly	9-1
4-2 FRONT COMPARTMENT COVER	4-2	9-1.5 Panel Installation	9-1
4-2.1 Cover Removal	4-2	9-2 HORN REPLACEMENT	9-1
4-2.2 Cover Installation	4-2	9-3 LOWERING BUZZER REPLACEMENT	9-3
4-3 REAR COMPARTMENT COVER	4-2	9-4 LEVEL SENSOR BUZZER REPLACEMENT	9-3
4-3.1 Cover Removal	4-2	9-5 LEVEL SENSOR REPLACEMENT	9-3
4-3.2 Cover Installation	4-2	9-6 WARNING LIGHT REPLACEMENT	9-3
4-4 STEERING MOTOR	4-3	9-7 BLUE LIGHT REPLACEMENT	9-3
4-4.1 Motor Removal	4-3	9-8 BATTERY REPLACEMENT	9-4
4-4.2 Motor Installation	4-3	9-9 BATTERY CHARGER	9-4
5 BRAKE SERVICING	5-1	9-9.1 Removal	9-4
5-1 BRAKES	5-1	9-9.2 Installation	9-4
5-1.1 Brake Assembly Replacement	5-1	9-10 PLATFORM CABLE REPLACEMENT	9-5
		9-10.1 Three Stage Mast	9-5
		10 OPTIONAL EQUIPMENT	10-1
		10-1 INDUSTRIAL BATTERY	10-1
		11 ILLUSTRATED PARTS BREAKDOWN	11-1

SECTION 1 DESCRIPTION

1-1. INTRODUCTION.

This publication describes the 24 volt BG Zero Electric Access Vehicle by Blue Giant. Included are planned maintenance instructions, lubrication procedures, corrective maintenance procedures and a complete parts list with part location illustrations.

Users shall comply with all requirements indicated in applicable OSHA standards and the current edition of A.N.S.I. A92.6. By following these requirements and the recommendations contained in this manual, you will receive many years of dependable service from your BG Zero Electric Access Vehicle.

1-2. GENERAL DESCRIPTION.

The self-propelled BG Zero Electric Access Vehicle lifts and transports up to 750 pounds capacity including load and operator. The vehicle enables general maintenance work and efficient selection and moving of materials in any area or at any level of the warehouse or storeroom. This vehicle is not for use on mezzanines or balcony areas. The design permits one man to perform all operations of selecting stock, driving vehicle, and replacing the stock at the designated place. The battery-powered vehicle is quiet and allows operation in closed areas without special provisions for ventilation.

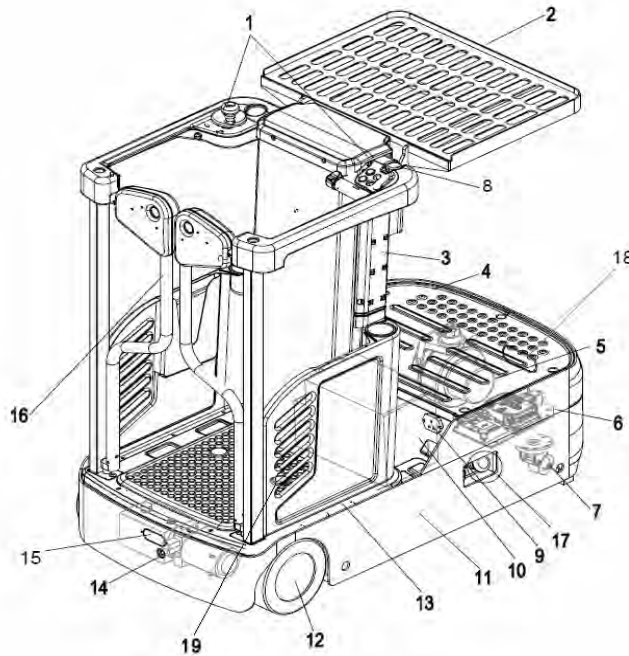

R8521

Figure 1-1 BG Zero Elevating Work Platform

ITEM	COMPONENT
1	Control panels
2	Storage tray
3	Lift mast
4	Lower storage tray
5	Drive wheel
6	Controller
7	Caster
8	Emergency stop switch
9	Charger socket

ITEM	COMPONENT
10	Battery
11	Frame
12	Load wheels
13	Operator platform
14	Hydraulic pump assembly
15	Warning light
16	Access gates
17	Emergency operation area
18	Blue Lamp
19	"Deadman" foot switch

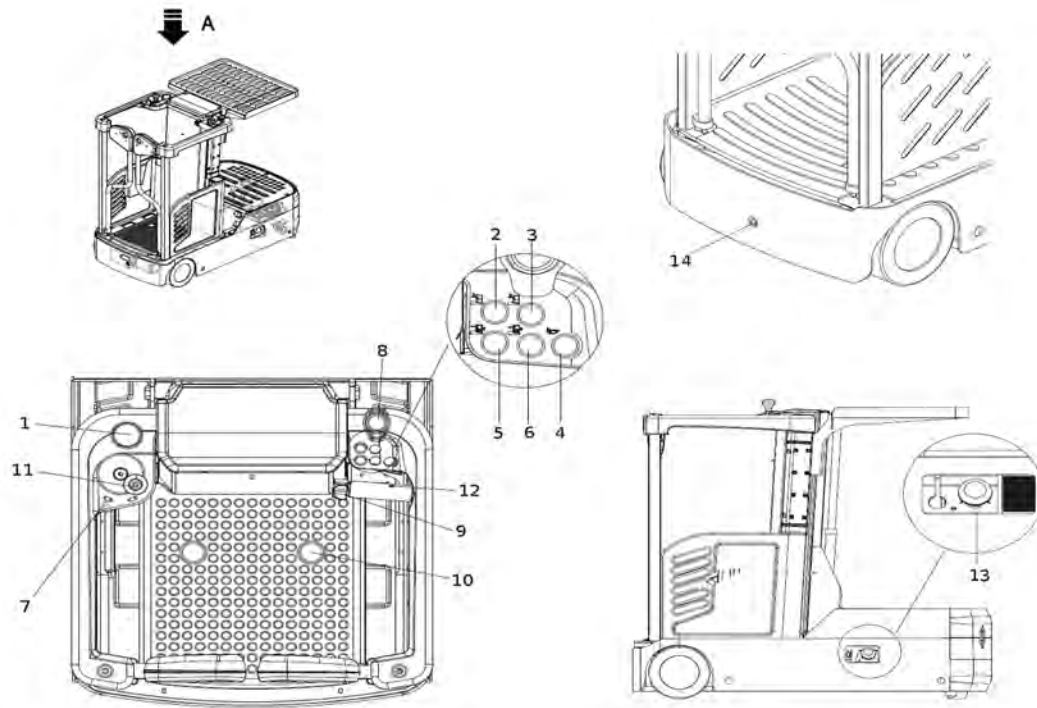

Figure 1-2

ITEM	CONTROL / DISPLAY	FUNCTION
1	Display unit	Operating information and alarm fault on display.
2	Lift button (tray)	Lift the storage table.
3	Lowering button (tray)	Lower the storage table.
4	Horn button	Activates the horn.
5	Lift button (platform)	Lift the lift platform.
6	Lowering button (platform)	Lower the lift platform.
7	Key switch	Switches control current on and off. Removing the key prevents the order picker from being switched on by unauthorized personnel.
8	Emerg. power disconnect switch	Disconnects the supply current, deactivates all electrical functions, causing the order picker to brake automatically.
9	Travel switch	Select the required driving direction.
10	Right "Deadman switch	Apply the right drive pedal to start up the order picker.
11	Steering wheel	Steers the order picker in the required direction.
12	Sensor switch for accelerator	The right hand must be placed in the position of the sensor switch to drive the order picker to move.
13	Emerg. power disconnect switch	Disconnects the supply current, deactivates all electrical functions, causing the order picker to brake automatically.
14	Emergency lowering valve	Used to manually lowering the platform.

The motor propels the vehicle in forward or reverse direction. The vehicle can be driven with the platform raised or lowered; however the speed is restricted above 20”.

On demand power steering makes the vehicle highly maneuverable.

The control arms are used to operate the work vehicle and provide operator safety.

The pick tray is used to place and transport merchandise, equipment and tools.

The operator platform contains the “Deadman” footswitch which must be depressed for the vehicle to operate.

1-3. DATA PLATE AND WARNING DECAL.

Warning decals are located on the mast cover. The name plate is mounted on the center of the mast cover.

If the data plate or warning decals are lost or damaged they MUST be replaced immediately. Have your

supervisor or the designated authority contact Blue Giant Authorized Dealer for replacement.

The data plate shows the model, serial number, capacity, lift height, vehicle weight and minimum battery weight. See [Figure 1-3](#).

1-4. INSTALLATION / WARRANTY CHECK LIST.

The Blue Giant Installation and Warranty Registration Reports are used to initiate the start of the warranty period to the original end user.

This report also serves as documentation that all items on the Installation and Warranty Registration Report were reviewed and discussed with the end user prior to taking receipt of the equipment.

This report must be completed and returned to Blue Giant within fifteen (15) days of receipt of equipment.

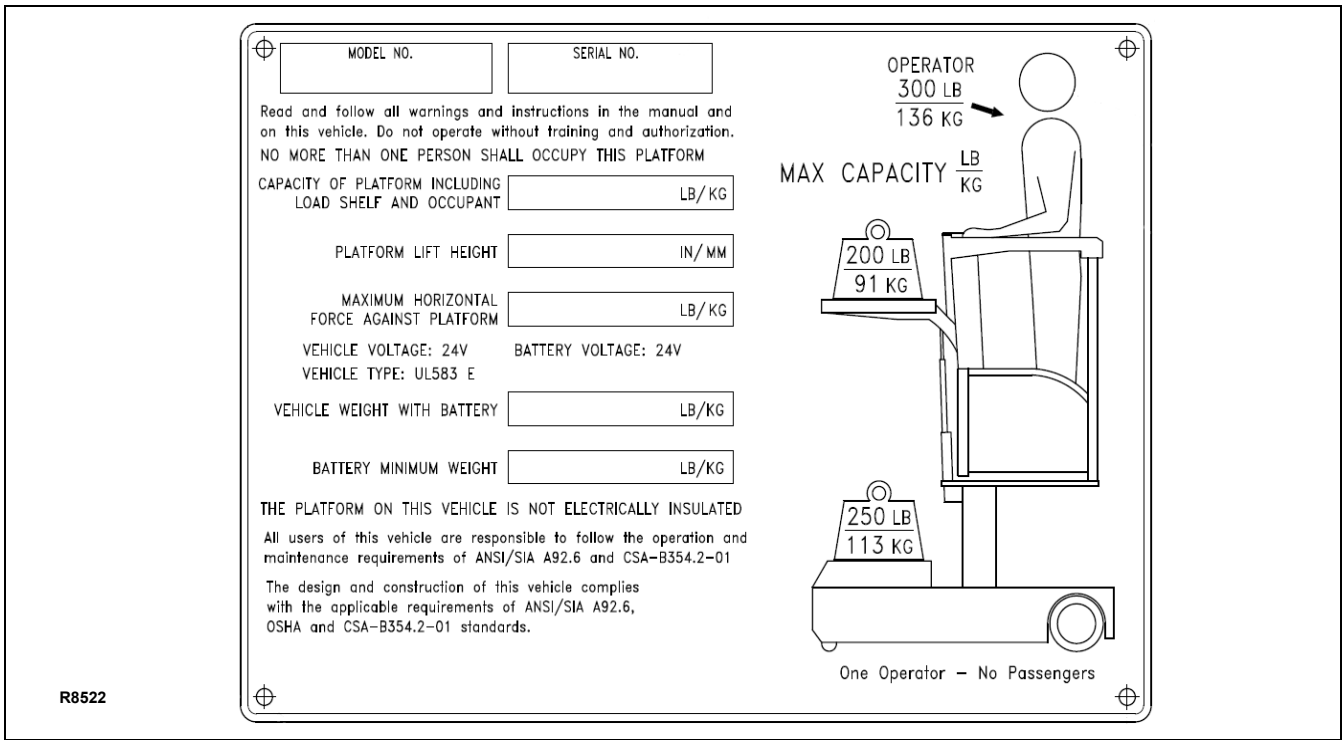

Figure 1-3 BG Zero Data Plate



Warranty Claim Form

ATTN: WARRANTY MANAGER Email: customersupport@bluegiant.com

Dealer ID #	Dealer Name	Claim Form Date (MM/DD/YYYY)	
Has Unit Been Maintained / Lubricated as Specified in Accordance with Owner's Manual?			
Yes <input type="checkbox"/>		No <input type="checkbox"/>	
Equipment Model #	Serial #	Customer	
Date of Equipment Sale (MM/DD/YY)	Hour Meter Reading	Customer Address	
Equipment Purchase Invoice #	Dealer Repair Order #	City / State / Province	
Submitted By (Print Full Name)	Title	Zip / Postal Code	
Phone:	Fax:	Email:	
Labor Total Hours:	Rate:	Labor Total: \$	Start Date (MM/DD/YY)
Travel Total Hours:	Rate:	Labor Total: \$	Start Date (MM/DD/YY)
Description of Fault:			
Nature of Fault:			
Corrective Procedure (Full Details Required, Incomplete Information will Delay Process)			

Blue Giant Part #	Part Description	QTY.	Blue Giant Replacement Part(s) Invoice Number(s)	Price	Total
				\$	\$
				\$	\$
				\$	\$
				\$	\$
				\$	\$
Freight <input type="checkbox"/> P <input type="checkbox"/> E <input type="checkbox"/>	The totals calculated on this form are estimates only. Warranty guidelines may apply. Final totals will appear on your warranty invoice. Please go to www.BlueGiant.com for Warranty Coverage and Warranty Guidelines for your product.			\$	\$

GL #

WC #

RG#

A confirmation receipt will be faxed back with a warranty claim number attached. If Blue Giant deems that part(s) need to be returned, an RGA numbered form will be faxed as well. Please include a copy of the RGA form with returning part(s) to Blue Giant Brampton location only.

SECTION 2 PLANNED MAINTENANCE

2-1. GENERAL.

Planned maintenance consists of periodic visual and operational checks, inspection, lubrication, and scheduled maintenance designed to catch an issue in the early hours or discover malfunctions and defective parts. The operator performs the checks in the Operator's Manual, and refers any required servicing to a qualified maintenance technician who performs the planned maintenance and any required servicing.

2-2. MONTHLY AND QUARTERLY CHECKS.

Table 2-1 is a monthly and quarterly inspection and service chart based on normal usage of equipment eight hours per day, five days per week. If the vehicle is used in excess of forty hours per week, the frequency of inspection and service should be increased accordingly. These procedures must be performed by a qualified service technician or your Blue Giant Service Representative.

2-3. FREQUENT INSPECTIONS.

The owner and user are required by ANSI A92.6 to ensure frequent inspections of the BG Zero Electric Access Vehicle occur and are performed in accordance with the following points: 1. If purchased used unless it's determined that the frequent and annual inspections are current. 2. The BG Zero Electric Access Vehicle has been in service for three (3) months or 150 hours, whichever comes first. 3. The BG Zero Electric Access Vehicle has been out of service for a period longer than three (3) months. inspection is to be performed by a mechanic that is qualified and authorized to perform service on the BG Zero Electric Access Vehicle. All service records must be maintained.

2-4. ANNUAL INSPECTIONS.

The owner and user are required by ANSI A92.6 to ensure annual inspections of the BG Zero Electric Access Vehicle occur and are performed no later than 13 months from the date of prior annual inspection or every 700 hundred hours of use, whichever occurs first. This annual inspection is to be performed by a mechanic that is qualified and authorized to perform service on the BG Zero Electric Access Vehicle. All service records must be maintained.

2-5. BATTERY CARE.

2-5.1. General

The vehicle may be equipped with maintenance free batteries.

The care and maintenance of the battery is very important to obtain efficient vehicle operation and maximum battery life.

CAUTION: Gases produced by a battery can be explosive. Do not smoke, use an open flame, create an arc or sparks in the vicinity of the battery. Ventilate an enclosed area well when charging.

CAUTION: Batteries contain sulfuric acid which may cause severe burns. Avoid contact with eyes, skin or clothing. In case of contact, flush immediately and thoroughly with clean water. Obtain medical attention when eyes are affected. A baking soda solution (one pound to one gallon of water) applied to spilled acid until bubbling stops, neutralizes the acid for safe handling and disposal.

Table 2-1 Monthly and Quarterly Inspection and Service Chart

VISUAL CHECKS	
INTERVAL	INSPECTION OR SERVICE
Monthly	Check electrical brake for proper operation.
Monthly	Inspect wiring for loose connections and damaged insulation.
Monthly	Check wheels for wear and damage.
Monthly	Check "deadman" footswitch for proper operation.
Monthly	Check lift chain tension, lubrication & operation (see paragraph 2-9.)
Quarterly	Check lift cylinder for leakage.
Quarterly	Test electric steering.
Quarterly	Check steering gear for wear and lubricate.
Semi-annually	Inspect for chain wear (See SECTION 7)

2-5.2. Safety Rules

- Wear protective clothing, such as rubber apron, gloves, boots and goggles when performing any maintenance on batteries. Do not allow electrolyte to come in contact with eyes, skin, clothing or floor. If electrolyte comes in contact with eyes, flush immediately and thoroughly with clean water. Obtain medical attention immediately. Should electrolyte be spilled on skin, rinse promptly with clean water and wash with soap. A baking soda solution (one pound to one gallon of water) will neutralize acid spilled on clothing, floor or any other surface. Apply solution until bubbling stops and rinse with clean water.
- Do not bring any type of flame, spark, etc., near the battery. Gas formed while the battery is charging, is highly explosive. This gas remains in cell long after charging has stopped.
- Do not lay metallic or conductive objects on battery. Arcing will result.
- Do not touch non-insulated parts of DC output connector or battery terminals to avoid possible electrical shock.
- Disconnect all AC and DC power connections before servicing battery.
- Do not charge a frozen battery.
- Do not use charger if it has been dropped or otherwise damaged.

2-5.3. Maintenance Personnel

Batteries may only be charged, serviced or replaced by trained personnel. This manual and the manufacturer's instructions concerning batteries and charging stations must be observed when carrying out the work.

2-5.4. Battery Care and Charging

CAUTION: Never smoke or bring open flame near the battery. Gas formed during charging is highly explosive and can cause serious injury.

1. Charge the battery only in areas designated for that use.
2. Battery terminals should be checked and cleaned of corrosion regularly. Good battery terminal contact is essential not only for operation, but also for proper charging of the battery.
3. Make certain battery used meets weight and size requirements of vehicle. NEVER operate vehicle with an undersized battery.

2-5.5. Battery Cleaning

Wipe batteries with a clean rag.

2-5.6. Maintenance Free Batteries

Some vehicles may be equipped with maintenance free batteries. These batteries are completely sealed, will not require any watering and have a full 80% discharge available.

Sealed Maintenance Free batteries contain a pressure release valve and under normal operating conditions do not require any special ventilation.

CAUTION: Do not try to open this battery or remove the pressure release valve.

Only under severe overcharging, such as connected to an improperly sized charger, will any significant amount of gases be released from the battery. Also, being a valve regulated battery, it never requires watering.

2-6. CHARGING BATTERIES

Charging requirements will vary depending on depth of discharge and temperature. Follow safety rules when placing a battery on charge.

Proceed as follows:

1. Park vehicle at charging station with platform lowered and turn the key switch OFF.
2. Apply the emergency disconnect switch.
3. Check the condition of the cord. If there are any cuts in the cord, any exposed wires, loose plugs or connectors, DO NOT attempt to charge the batteries.
4. Connect plug from the vehicle to a power outlet and charge the battery according to Supplement 374 *.

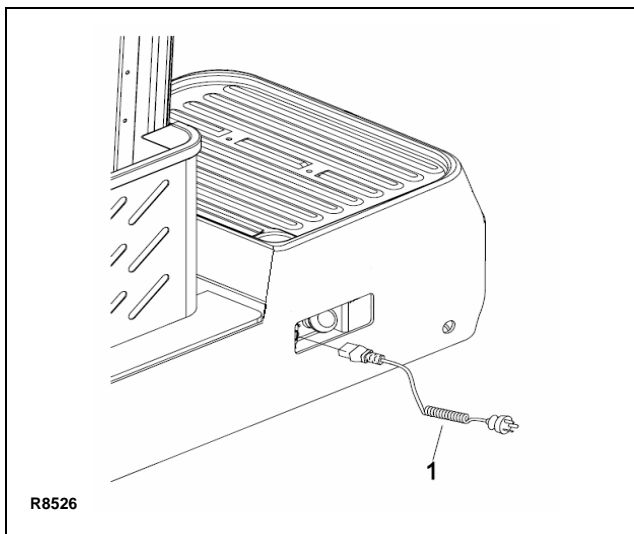

Figure 2-1 Battery Charging

2-7. REPLACING BATTERIES

1. Engage the emergency power disconnect switch and turn off key switch.
2. Remove the compartment cover as described in paragraph 4-2.1.
3. Remove the four screws, lock washers and flat washers that holds the battery brackets in place.

4. Disconnect the battery cables from the batteries.
5. Carefully lift the batteries out of the vehicle.
6. for installation please reverse step 1-5.

Replace only with original OEM batteries or batteries approved by an authorized Blue Giant dealer. Contact your authorized Blue Giant dealer for information on optional batteries and battery chargers.

WARNING: The weight and dimensions of the battery have considerable affect on the operational safety of the vehicle. Battery equipment may only be replaced with the agreement of the manufacturer.

2-7.1. Battery disposal:

Dispose in accordance with national environmental protection regulations or disposal laws. The manufacturer's disposal instructions must be followed

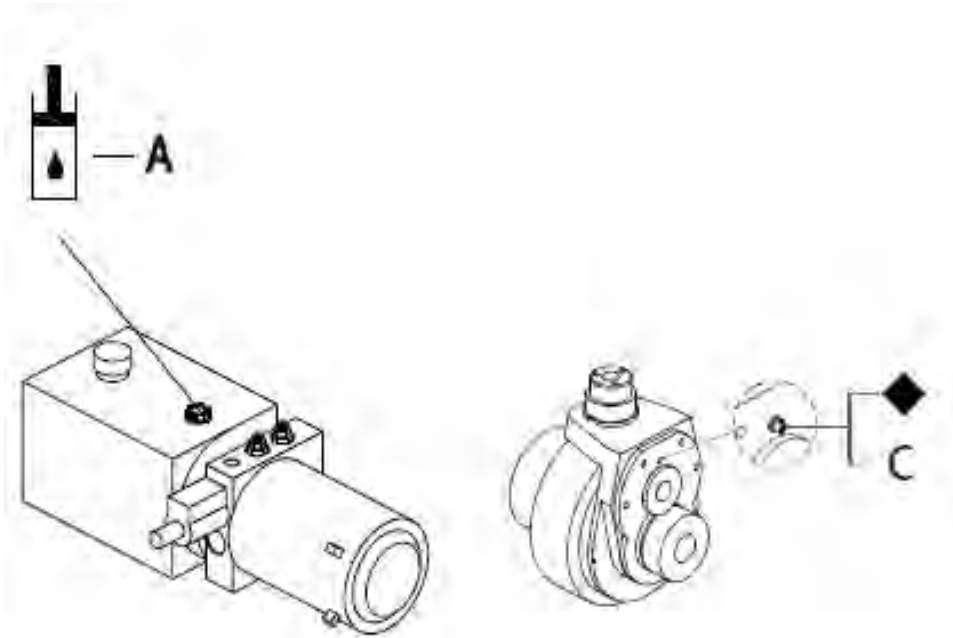

R8527

Figure 2-2 Lubrication Diagram

2-8. LUBRICATION.

Refer to [Table 2-2](#) for the recommended types of grease and oil. [Table 2-3](#) in conjunction with [Figure 2-2](#) identifies the items requiring lubrication.

**Table 2-2 Recommended Lubricants
(See [Table 2-3](#) for Application)**

No. 1	Grease - Polylube GA352P
A	Hydraulic oil - L-HM46#.
C	Grease(contain Mus2)

2-9. LIFT CHAIN MAINTENANCE.

Fully raise and lower lift carriage while observing chains as they move over chain sheaves. Ensure chain is aligned and tracking properly and all links are pivoting freely. With lift carriage fully lowered, spray on a film of Moly Chain Lube. For more information see [SECTION 7](#)

Table 2-3 Lubrication Chart

FIG 3-2 INDEX NO.	LOCATION	METHOD OF APPLICATION	TYPE (Table 2-3)	APPLICATION OF LUBRICANT
1	Mast	Spray	No. 1	Full length of channel where rollers operate.
2	Hydraulic Reservoir	Can	A	With platform fully lowered, fill reservoir with hydraulic oil to level on dip stick.
3	Gearbox	Tube	C	Grease gun



Annual Inspection Report

DEALER INFORMATION				OWNER / END USER INFORMATION			
COMPANY:				COMPANY:			
ADDRESS:				ADDRESS:			
CITY/STATE/ZIP:				CITY/STATE/ZIP:			
VEHICLE INFORMATION:							
MODEL:		SERIAL:		MAST SIZE:		HOUR METER:	
BATTERY SPEC.:		OPTIONS:		PREVIOUS INSPECTION:			

INSPECTION REQUIREMENTS per ANSI A92.6 (ANNUAL AND FREQUENT)
ANNUAL INSPECTION: The owner and user are required by ANSI A92.6 to ensure annual inspections of the BG Zero Task Support Vehicle occur and are performed no later than 13 months from the date of prior annual inspection or every 700 hundred hours of use, whichever occurs first. This annual inspection is to be performed by a mechanic that is qualified and authorized to perform service on the BG Zero Task Support Vehicle. All service records must be maintained.
FREQUENT INSPECTIONS: The owner and user are required by ANSI A92.6 to ensure frequent inspections of the BG Zero Task Support Vehicle occur and are performed in accordance with the following points: 1. If purchased used unless it's determined that the frequent and annual inspections are current. 2. The BG Zero Task Support Vehicle has been in service for three (3) months or 150 hours, whichever comes first. 3. The BG Zero Task Support Vehicle has been out of service for a period longer than three (3) months. inspection is to be performed by a mechanic that is qualified and authorized to perform service on the BG Zero Task Support Vehicle. All service records must be maintained.
INSTRUCTIONS: Refer to service/maintenance manuals for specific information regarding inspection procedures and criteria. Indicate in the appropriate space as each item has been performed. If the item is found to be not acceptable, describe each discrepancy on an additional page and attach to the form. Immediate action must be taken to correct all discrepancies. The vehicle shall not be placed in service until all discrepancies have been corrected.

Put a ✓ in the column that applies: P = Passed Inspection , F = Failed Inspection, C = Corrected			
FUNCTIONS and CONTROLS	P	F	C
Drive and operate machine to test all functions. Ensure controls operate properly and return to "off" or neutral when released.	<input type="checkbox"/>	<input type="checkbox"/>	<input type="checkbox"/>
Ensure emergency power disconnect switch deactivates all movement and power and that the deadman foot switch operate properly.	<input type="checkbox"/>	<input type="checkbox"/>	<input type="checkbox"/>
Instrument panel is clean and free of debris and dash display is functional.	<input type="checkbox"/>	<input type="checkbox"/>	<input type="checkbox"/>
Operator right side control arm functions properly. Horn / travel / lift / lower / accelerator buttons are functional.	<input type="checkbox"/>	<input type="checkbox"/>	<input type="checkbox"/>
Operator left side control arm steering wheel functions properly.	<input type="checkbox"/>	<input type="checkbox"/>	<input type="checkbox"/>
Emergency lower button operates properly.	<input type="checkbox"/>	<input type="checkbox"/>	<input type="checkbox"/>
Ensure gate switches disable travel/lift and lower functions and flashing lights on the front and rear of the vehicle.	<input type="checkbox"/>	<input type="checkbox"/>	<input type="checkbox"/>
The drive wheel returns to "neutral" (straight forward) when powering up the vehicle and is accurately depicted on the LCD display.	<input type="checkbox"/>	<input type="checkbox"/>	<input type="checkbox"/>
OPERATOR PLATFORM ASSEMBLIES	P	F	C
Mast sections are free of visual evidence of damage. Mast chains and cables are inspected per the Service and Maintenance Manual.	<input type="checkbox"/>	<input type="checkbox"/>	<input type="checkbox"/>
Mast wiring harnesses are properly installed, seated in their pulleys and that there are no frayed or broken strands.	<input type="checkbox"/>	<input type="checkbox"/>	<input type="checkbox"/>
Chains are adequately lubricated and are not dry or rusty.	<input type="checkbox"/>	<input type="checkbox"/>	<input type="checkbox"/>
Mast cover plates are in place and securely attached for each section.	<input type="checkbox"/>	<input type="checkbox"/>	<input type="checkbox"/>
Mast operates smoothly to full height and descends smoothly. Ensure speed cutbacks occur at appropriate heights per the maintenance manual.	<input type="checkbox"/>	<input type="checkbox"/>	<input type="checkbox"/>
Platform guard rails are undamaged and gates open / close freely.	<input type="checkbox"/>	<input type="checkbox"/>	<input type="checkbox"/>
All nuts, bolts, pins, shafts, covers, bearings and wear pads are checked for proper installation, and do not have excessive wear, cracks or distortion.	<input type="checkbox"/>	<input type="checkbox"/>	<input type="checkbox"/>

Continued on page 2



Annual Inspection Report

VEHICLE INFORMATION:			
MODEL:		SERIAL:	
DEALER:		MAST SIZE:	
		OWNER / END USER:	
			HOUR METER:

HYDRAULIC SYSTEM	P	F	C
Lift cylinder is free of damage, no evidence of leaks and that all hardware is secure and undamaged.	<input type="checkbox"/>	<input type="checkbox"/>	<input type="checkbox"/>
All hydraulic hoses, fittings and components are properly secured and that there is no evidence of leaks.	<input type="checkbox"/>	<input type="checkbox"/>	<input type="checkbox"/>
Ensure fluid level is correct in hydraulic tank.	<input type="checkbox"/>	<input type="checkbox"/>	<input type="checkbox"/>
Ensure hydraulic pump is secure and undamaged, operates properly and is free of leaks.	<input type="checkbox"/>	<input type="checkbox"/>	<input type="checkbox"/>
Ensure hydraulic control valve is secure and undamaged, operates properly and is free of leaks.	<input type="checkbox"/>	<input type="checkbox"/>	<input type="checkbox"/>
Ensure hydraulic oil breather/vented cap is clean, hydraulic tank cap is tight and vent is open.	<input type="checkbox"/>	<input type="checkbox"/>	<input type="checkbox"/>
POWER and DRIVE SYSTEM	P	F	C
Ensure battery fluid level is correct (if applicable).	<input type="checkbox"/>	<input type="checkbox"/>	<input type="checkbox"/>
Visually inspect motors to ensure there is no damage.	<input type="checkbox"/>	<input type="checkbox"/>	<input type="checkbox"/>
Ensure battery charger scrolls through diagnostics when plugged in.	<input type="checkbox"/>	<input type="checkbox"/>	<input type="checkbox"/>
Ensure all electrical connections are tight, free of frays and corrosion.	<input type="checkbox"/>	<input type="checkbox"/>	<input type="checkbox"/>
Ensure battery meets weight and voltage requirements.	<input type="checkbox"/>	<input type="checkbox"/>	<input type="checkbox"/>
Ensure drive, load and caster wheels are properly installed, secure and do not have excessive wear.	<input type="checkbox"/>	<input type="checkbox"/>	<input type="checkbox"/>
Ensure all five wheels have contact with the floor.	<input type="checkbox"/>	<input type="checkbox"/>	<input type="checkbox"/>
Ensure the electronic brake operates properly.	<input type="checkbox"/>	<input type="checkbox"/>	<input type="checkbox"/>
GENERAL	P	F	C
Ensure paint is in good condition and that there are not any issues with the overall appearance of the task support vehicle.	<input type="checkbox"/>	<input type="checkbox"/>	<input type="checkbox"/>
Inspect overall structural condition including welds.	<input type="checkbox"/>	<input type="checkbox"/>	<input type="checkbox"/>
Verify that no unauthorized modifications or additions have been made.	<input type="checkbox"/>	<input type="checkbox"/>	<input type="checkbox"/>
Grease and lubricate the mast channel per maintenance manual.	<input type="checkbox"/>	<input type="checkbox"/>	<input type="checkbox"/>
Ensure stability pads at base of unit (adjacent to caster wheels) are intact, properly secured and have not sustained any damage	<input type="checkbox"/>	<input type="checkbox"/>	<input type="checkbox"/>
Ensure optional equipment such as anchor point, tether, full body harness and tow hitch are in good condition and fully functional (if applicable).	<input type="checkbox"/>	<input type="checkbox"/>	<input type="checkbox"/>
Inspect front and rear load trays for functionality and damage.	<input type="checkbox"/>	<input type="checkbox"/>	<input type="checkbox"/>
MANUALS - DECALS - DATA PLATE	P	F	C
Ensure ANSI/ SIA A92.6 manual of responsibilities, operations manual and service manual are in weather resistant pouch on vehicle.	<input type="checkbox"/>	<input type="checkbox"/>	<input type="checkbox"/>
Ensure data plate is in place, secured and legible	<input type="checkbox"/>	<input type="checkbox"/>	<input type="checkbox"/>
Ensure all instruction and safety decals are installed, secure and legible.	<input type="checkbox"/>	<input type="checkbox"/>	<input type="checkbox"/>
ADDITIONAL COMMENTS			

The undersigned certifies that this machine has been inspected, per each area of inspection, and any and all discrepancies have been brought to the attention of the Owner / User, and that all discrepancies have been corrected prior to any further use of this machine.

OWNER / USER	OWNER / USER	
SIGNATURE:	PRINTED NAME:	DATE:
DEALER	DEALER	
SIGNATURE:	PRINTED NAME:	DATE:

SECTION 3 TROUBLESHOOTING

3-1. GENERAL

Use [Table 3-1](#) as a guide to determine possible causes of trouble. The table is divided into five main categories: Vehicle and Hydraulic System Will Not

Operate: Vehicle Does Not Operate Forward or Reverse: Trouble With Braking: Trouble With Lifting Or Lowering, and Miscellaneous malfunctions.

Table 3-1 Troubleshooting Chart

MALFUNCTION	PROBABLE CAUSE	CORRECTIVE ACTION
<p>TRAVEL AND HYDRAULIC SYSTEM WILL NOT OPERATE</p>	<ul style="list-style-type: none"> a. Battery connections not connected. b. Keyswitch "OFF" or defective. c. Safety access gate open. d. Emergency power disconnect switch pressed or defective. e. "Deadman" footswitch not pressed or defective. f. Battery charge too low. g. Faulty fuse. 	<ul style="list-style-type: none"> Check the battery connections and connect if necessary. Turn keyswitch "ON" or bypass keyswitch to determine if it is malfunctioning. Close access gates. Disengage the emergency power disconnect switch or bypass switch to determine if it is malfunctioning. Press "deadman" footswitch or bypass pedal to determine if it is malfunctioning. Check battery charge, charge battery if necessary. Test fuses.
<p>VEHICLE DOES NOT OPERATE FORWARD OR REVERSE</p> <ul style="list-style-type: none"> • Vehicle does not travel forward or reverse. All other functions operate normally. • Vehicle travels forward but not in reverse. • Vehicle travels reverse but not in forward. • Vehicle travels forward and in reverse at lower speeds; will not travel at high speed. 	<ul style="list-style-type: none"> a. Check all wiring. A loose connection may be the cause of malfunction. c. Defective controller. d. Defective travel switch. Defective travel switch. Defective travel switch in control head. a. Defective travel switch in control head. b. Operator platform raised above 20 inches. 	<ul style="list-style-type: none"> Tighten all loose connections before further troubleshooting. Check for proper operation and replace if necessary. Check and replace switch if defective. Check and replace switch if defective. Check and replace switch if defective. Check and replace switch if defective. Lower operator platform below 20 inches

Table 3-1 Troubleshooting Chart - Continued

MALFUNCTION	PROBABLE CAUSE	CORRECTIVE ACTION
<p>TROUBLE WITH LIFTING OR LOWERING</p> <ul style="list-style-type: none"> • Oil sprays or flows from the top of the lift cylinder. • Squealing sounds when lifting Operator's platform. • Platform does not lift to full lift height. • Weak, slow or uneven action of hydraulic system. • Platform does not lift, pump motor does not run. 	<p>Defective packing in lift cylinder</p> <p>a. Oil level too low. b. Dry channels in mast. c. Defective mast or Platform rollers</p> <p>a. Oil level too low. b. Load larger than capacity.</p> <p>a. Defective pump or relief valve. b. Worn lift cylinder. c. Load larger than capacity. d. Defective lift motor relay. e. Battery charge low.</p> <p>a. Battery is dead or disconnected. b. Defective wiring. c. Defect in electrical system for operating pump motor.</p>	<p>Repair lift cylinder.</p> <p>Identify oil leak and fill reservoir. Apply grease. Replace rollers.</p> <p>Add oil to reservoir. Refer to I.D.plate for capacity.</p> <p>Check pressure. Adjust as necessary. Replace cylinder. Refer to I.D.platefor capacity. Replace relay on pump motor. Charge battery.</p> <p>Check and recharge if required.</p> <p>Check and repair as required. Check lift switch on platform, as well as the relay.</p>
<ul style="list-style-type: none"> • Platform does not lift, motor runs. • Platform lifts, but will not go down. • Load will not hold • Platform does not lift to top. Pump motor runs. • Forks drifts down under load when in a raised position. 	<p>Defect in hydraulic system.</p> <p>Defect in hydraulic system</p> <p>a. Oil bypassing internally in control valve b. Worn lift cylinder or packing.</p> <p>a. Oil level too low. b. Load larger than capacity.</p> <p>c. Batteries need charging. Leak in hydraulic system, lift cylinder or lowering valve.</p>	<p>Check the oil level in the reservoir and the oil lines to the lift cylinder, and repair as required. If normal, check the hydraulic pump, and relief valve. Repair, or adjust.</p> <p>Check lowering control switch and lowering solenoid. Replace as required.</p> <p>Replace valve assembly.</p> <p>Repack cylinder.</p> <p>Add oil to reservoir. Refer to nameplate on side of mast for maximum load capacity. Charge batteries.</p> <p>Check for leaking fitting in hydraulic line and repair as required. Repack lift cylinder or replace valve assembly.</p>

Table 3-1 Troubleshooting Chart - Continued

MALFUNCTION	PROBABLE CAUSE	CORRECTIVE ACTION
TROUBLE WITH STEERING	<ul style="list-style-type: none"> a. Faulty fuse. b. Check all wiring. A loose connection may be the cause of malfunction. c. Defective potentiometer. d. Defective controller. e. Defective STEERING motor. 	<ul style="list-style-type: none"> Test fuses. Tighten all loose connections before further troubleshooting. Check and replace potentiometer if defective. Check for proper operation and replace if necessary. Replace if necessary.

3-2. CONTROLLER TROUBLESHOOTING

3-2.1. Zapi Handset

A Zapi Handset is available that is designed specifically for use with the Zapi controller. It serves multiple functions of reading diagnostic data, testing vehicle operation, setting options, adjustments and parameter changes of the controller. The Zapi Handset is available through your Blue Giant dealer. If you require dealer location information, contact Blue Giant.



Figure 3-1 Zapi Controller

3-2.2. Fault Detection.

3-2.2.1. General

The microprocessor in the controller records the last five Alarms that have occurred. Items remembered relative to each Alarm are:

- The alarm code
- The times that each alarm occurs consecutively
- The Hour Meter value when the latest event of every alarm occurred

This function permits a deeper diagnosis of problems as the recent history can be revisited.

3-2.2.2. Logbook Access

Locate the 4 Pin Can Connection on the harness next to the Zapi controllers.

1. Push & press the Power On Button for 3s the display will show **Cons AFG ZPxxxx**
2. Press the \wedge or \vee button until CAN CONSOLE shows on the display.
3. The display will show:
Cons AFG ZP021* CAN CONSOLE
Press OK to go into the CANSOOLE Menu.
4. The display will show:
SELECT NODE NODE 2
Press OK to go into the Traction controller.
5. The display will show:
PDXT1 ECK EP0.54
Press OK to go into the Main Menu. **Main Menu**
press \wedge or \vee button to go the Alarms menu then press OK.
6. To clear the Alarm faults press the F1 button, it will ask if you are sure press OK, then the ECS Button.





3-2.3. Testing Vehicle Operation.

Locate the 4 Pin Can Connection on the harness next to the Zapi controllers

1. Push & press the Power On Button for 3s the display will show **Cons AFG ZPxxxx**
2. Press the \wedge or \vee button until CAN CONSOLE shows on the display.
3. The display will show:
Cons AFG ZP021* CAN CONSOLE
Press OK to go into the CANSOOLE Menu.
4. The display will show:
SELECT NODE NODE 2
Press OK to go into the Traction controller.
5. **The display will show:**
PDXT1 ECK EP0.54
Press OK to go into the Main Menu.
Main Menu
press \wedge or \vee to **TESTER**,
press OK and you can test and see the status of the electrical system.
6. Press the **ESC** button to get out of that menu

3-2.4. Factory Settings

Parameter setting are not to be changed from factory settings without explicit written permission from Blue Giant. To verify the parameter settings proceed as follows and refer to [Table 3-2: Locate the 4 Pin Can Connection on the harness next to the Zapi controllers](#)

1. Push & press the Power On Button for 3s the display will show: **Cons AFG ZPxxxx**
2. Press the  or  button until CAN CONSOLE shows on the display.
3. The display will show:
Cons AFG ZP021* CAN CONSOLE
Press OK to go into the CANSOOLE Menu.
4. **The display will show:**
SELECT NODE NODE 2
Press OK to go into the Traction controller.
5. **The display will show:**
PDXT1 ECK EP0.54
Press OK to go into the Main Menu.
Main Menu press  or  to **PARAMETER CHANGE,**

press OK and you can adjust Parameters in the electrical system.

6. Press the **ESC** button to get out of that menu, it will ask you Do you want to save changes press OK to apply the changes.
- 7.



Figure 3-2 Zapi Handset

ACCELER. DELAY	2
RELEASE BRAKING	2
RELEASE BRK STER	0.1
TILLER BRAKING	0.1
INVERS. BRAKING	0.5
DECEL. BRAKING	1
SPEED LIMIT BRK.	1
BELLY BRAKING	0.5
STEER BRAKING	0.1
MAX SPEED FORW	100%
MAX SPEED BACK	100%
AUX LIFT SPEED	-100%
AUX LOWER SPEED	100%
AUX LIFT ACCELER	0.5
AUX LIFT DECELER	0.5
AUX LOWER ACCEL.	0.5
AUX LOWER DECEL.	0.5
CUTBACK 1 A7 TIL	25%
CUTBACK 2 C7	20%

Table 3-3 Troubleshooting Chart (Traction/Lift Controller)

Display Alarm	MDI Alarm	Flash 1	Flash 2	Alarm	Description	Diagnostics
8	8	1	1	Watch Dog	The embedded WATCH DOG protection is not able either to cut off the power stage when not triggered or it is not able to activate the power stage when triggered	<ol style="list-style-type: none"> 1) Check the U, V & W motor cables from the controller to the motor 2) Make sure no wire or cable is connected between the main contactor and controller 3) Replace the controller
17	17	1	3	Logic Failure #3	It occurs when the circuit to limit via HW the current peak on the controller is active	<ol style="list-style-type: none"> 1) Recharge the battery and check the battery condition 2) Check the cables from battery to controller B+ and B- 3) Replace the controller
18	18	2	7	Logic Failure #2	It occurs when the circuit to compensate for dead times of the sine wave is failed	<ol style="list-style-type: none"> 1) Recharge the battery and check the battery condition at least 2.2 volts per cell 2) Check the cables from battery to controller B+ and B- 3) Replace the controller
19	19	2	6	Logic Failure #1	This fault is displayed when the controller detects an over or under voltage condition. Over voltage threshold is 35V, the under voltage threshold is 9.5V in the 24V controller. 65V in the 48V controller, 9.5 undervoltage in the controller	<ol style="list-style-type: none"> 1) Check for proper battery voltage at the battery and ensure it match's the voltage in the controller 2) Recharge the battery if 24 volts or less and load test to confirm the integrity of the battery(s) 3) Check the cables from battery to controller B+ and B- 4) Check the wires from the Key switch to the controller 5) Replace the controller
28	28	7	3	Pump VMN Low	This test is carried out hen the pump motor is turning (pwm applied). The pump motor out put is higher than expected, considering the pwm applied	<ol style="list-style-type: none"> 1) Check the motor cable connections 2) Check the motor windings or cables have continuity to the frame (isolate or replace shorted items) 3) If no problems are found in the motor or cabling replace the controller
29	29	7	4	Pump VMN High	The pump motor output is lower than expected, considering the pwm applied	<ol style="list-style-type: none"> 1) Check the motor cable connections 2) Check the motor windings or cables have continuity to the frame (isolate or replace shorted items) 3) If no problems are found in the motor or cabling replace the controller 4) Ensure the Line contactor is closing properly with good contact 5) If all above checks out ok replace the controller
30	30	1	5	VMN Low	Before the main contactor turns on the Soft Ware turns on sequence the Bottom side Power Mosfet transistors and expects the V phase voltage falls to ground, If the V phase remains high this alarm occurs	<ol style="list-style-type: none"> 1) Check the U,V,W motor cable connections for damage & proper connections 2) Check the motor windings or cables have continuity to the frame if the resistance is more than 100 Ω, replace the motor. If the resistance is less than 1Ω, check the motor, harness or cables are shorted to the frame. (isolate or replace shorted items) 3) If no problems are found in the motor or cabling replace the controller
31	31	1	8	VMN High	Before the main contactor turns on the Soft Ware turns on sequence the Top side Power Mosfet transistors and expects the V phase voltage increases to close the capacitor value , If the V phase does not increase the this alarm occurs. The main contactor is lost although it is closed	<ol style="list-style-type: none"> 1) Check the U,V,W motor cable connections for damage & proper connections 2) Check the motor windings or cables have continuity to the frame if the resistance is more than 100 Ω, replace the motor. If the resistance is less than 1Ω, check the motor, harness or cables are shorted to the frame. (isolate or replace shorted items) 3) If no problems are found in the motor or cabling replace the controller
37	37	5	6	Contactor Closed	The controller checks if the Line Contactor is closed when the coil is not driven, trying to discharge the capacitor bank. If they do not discharge, the alarm will appear	<ol style="list-style-type: none"> 1) Check the Line contactor, if it mechanically stuck or welded
38	38	2	3	Contactor Open	The Line contactor coil has been driven by the logic board but does not close	<ol style="list-style-type: none"> 1) Check if the wires are secure and have continuity 2) Check the resistance of the coil approximately 55Ω 3) Check if the contact tips are allowing proper current / voltage flow

Figure 3-2 Troubleshooting Chart (Traction/Lift Controller) - Continued

Display Alarm	MDI Alarm	Flash 1	Flash 2	Alarm	Description	Diagnostics
49	49	7	5	PUMP I + 0 EVER	The current feed back sensor is not constantly stuck to 0 when the motor is running	<ol style="list-style-type: none"> 1) Check the motor for shorts to frame, opens, stuck motor brush's 2) Check the current sensor and related wiring 3) Check the line contactor
53	53	2	2	STBY HIGH		Replace the controller
60	60	1	4	Capacitor Charge	In an operating condition, a resistance between the Key and Rail Capacitors, keeps the rail Capacitor charged before the Line contactor closes. When the voltage on the Rail capacitors (measured on the V phase) is low and does not increase when the Line contactor is opened this alarm occurs	<ol style="list-style-type: none"> 1) Check the voltage and connections of the battery(s) 2) Check the continuity of the wiring form the Key switch to the controller 3) Disconnect all the wires and cables, connect a 100Ω resistor from B+ to B- for a while to bleed down the capacitor bank 4) Replace the controller
62	62	3	5	TH Protection	This alarm occurs when the temperature of the base plate is higher than 78° C / 172° Fahrenheit	<ol style="list-style-type: none"> 1) Allow the truck to sit for a few minutes in a room ambient temperature, clean the dust and dirt off the controller then re-check. If it is clean and ok, the Duty cycle / operating environment maybe to severe 2) Check the heat dissipation,check if the fan is operating properly and the heat sink compound grease is not liquified or runny 3) Ensure the brake is releasing properlyand not dragging or binding 4)Check the U,V, W cables are connected intheir proper positions and the drive motor is operating smoothley and properly 5) Replace the controller
65	65	3	8	Motor Temperature High	The temperatur of the drive motor windings are above the allowed setting	<ol style="list-style-type: none"> 1) Allow the truck to sit for a few minuites in a an room ambient temperature, clean the the dust and dirt off the controler then re-check. If it is clean and ok, the Duty cycle / operating enviroment maybe to to severe. 2) Ensure the brake is releasing properlyand not dragging or binding 3)Check the continuity of the wires for ther temperature sensor to frommotor to controller, and the restance of the sensor itself 4) Replace the controller if all above are ok
66	0	3	6	Battery Low	The battery is beow 24 volts	1) Check the battery voltage and ensure it match's the voltage in the controller setting
74	74	1	6	Driver Shorted	This occurs when the voltage on the Line contactor is higher than expexted, meaning the coil has high voltage not being supplied	<ol style="list-style-type: none"> 1) Check the wires between the Line contactor coil & the controller 2) Check the contactor operation 3) Replace the controller
75	75	3	4	Contactor Driver	Occurs when Voltage on the Line Contactor is less than expected, it means the coil has a null /0 voltage	<ol style="list-style-type: none"> 1) Chek the resitance of the coil 55Ω 2) Check the continuity of the coil wires to the controller 3)Replace the controller
78	78	3	3	VACC Not OK	The Accelerator in the Tester mode is higher than 1.0V in nuetral	<ol style="list-style-type: none"> 1) Recalibrate the VACC with a handset 2) Check the wiring between the Accellerator and the controller 3)Replace the Accellerator / VACC 4) Replace the controller
79	79	3	2	Incorrect Start	This is a Sequence waring notifying you something is requested prior to self check	<ol style="list-style-type: none"> 1) Restart the truck in the proper sequence, nothing being activated prior to the self check 2) Use a handset go in the Tester mode and check if any inputs are active when they should not be 3) Check the Line contactor 4) Replace the controller

Table 3-3 Troubleshooting Chart (Traction/Lift Controller) - Continued

Display Alarm	MDI Alarm	Flash 1	Flash 2	Alarm	Description	Diagnostics
80	80	3	1	FORW & BACK	Both travel directions requested at the same time	<ol style="list-style-type: none"> 1) Check the F&R Travel inputs via the Tester menu in the Zapi handset 2) Replace the controller
82	82	5	7	Encoder ErrorPedal Wire KO	Two consecutive readings of the Encoder speed are too great between he two	<ol style="list-style-type: none"> 1) Use the handset to check the Encoder operation (Slip Control) 2) Check if the Encoder is secured tightly in position 3) Check the instalation of the Encoder ensure it is properly in position 4) Check for debris or moisture in the Encoder 5) Check the wiring from the Encoder to the controller 6) Replace the encoder 7) Replace the controller if all the above are ok
86	86	1	1	Pedal Wire KO	Ther NPOT Voltage is less than 0.3V or grater than 2.0 VDC	<ol style="list-style-type: none"> 1) Check the voltage at the NPOT at the acclerator 2) Check the continuity of the wiries from the acclerator to the controller
197	90	10	7	Reach Pot Range	The controller receives voltage for the input prior to being operated	<ol style="list-style-type: none"> 1) Check the contiuity of the potentiometer wires down to the controller 2) Check the potetiometer function with a a handset
198	90	10	6	Reach Pot Range not OK	Controller can not receive the voltage signal input after the reach potentiometer is operated	<ol style="list-style-type: none"> 1) Check the contiuity of the potentiometer wires down to the controller 2) Check the potetiometer function with a a handset
199	0	10	5	End Teach Error	Contact Technical Support	
200	0	10	4	End Teach Ok		
201	0	10	3	Teach Error		
202	91	10	1	Prog LPOT Not OK		
203	33	6	4	Pump VMN not Ok	Pump motor output voltage is incorrect	<ol style="list-style-type: none"> 1) Cycle the Key switch off & On 2) Check the cables and connections on the pump motor & controller
204	63	5	4	Wait Mot.p Still	The Software is waiting for the pump motor to stop	<ol style="list-style-type: none"> 1) Check the cables and connections on the pump motor & controller 2) Replace the controller
205	70	8	5	EPS Rely Open	EPS Controller has a fault	<ol style="list-style-type: none"> 1) Check the Alarms in the EPS controller and diagnose from there
206	31	9	8	Init VMN High	Motor output voltage is higher than expected before drivivng	<ol style="list-style-type: none"> 1) Check the cabels from the pump motor to the controller
207	72	9	7	Init VMN Low	Motor output voltage is lower than expected before drivivng	<ol style="list-style-type: none"> 1) Check the cabels from the pump motor to the controller
208	13	9	5	Eeprom KO	Hardware or Software defect in the memory	<ol style="list-style-type: none"> 1) Save the settings in the Zapi handset, Clear the Eprom restoe settings if needed 2) Replace the controller
209	13	9	6	Param Restore	Controller programming has an issue	<ol style="list-style-type: none"> 1) Cycle the Keyswitch off & on 2) Save the settings in the Zapi handset, Clear the Eprom restoe settings if needed 3) Replace the controller
210	71	9	4	Wrong RAM Mem.	Controller RAM has an issue	<ol style="list-style-type: none"> 1) Cycle the Keyswitch off & on 2) Save the settings in the Zapi handset, Clear the Eprom restore settings if needed 3) Replace the controller
211	11	6	5	Stall Rotor	The gear for the Encoder in the motor is not working or moving	<ol style="list-style-type: none"> 1) Check the Encoder wirirng and operation with a Zapi handset 2) Jack the wheel up and check the rotor's operation

Figure 3-2 Troubleshooting Chart (Traction/Lift Controller) - Continued

Display Alarm	MDI Alarm	Flash 1	Flash 2	Alarm	Description	Diagnostics
212	10	8	3	Wrong RAM	Controller RAM has an issue	1) Cycle the Keyswitch off & on 2) Save the settings in the Zapi handset, Clear the Eprom restore settings if needed 3) Replace the controller
214	50	8	7	EVP Coil Open	No load to the Electric Valve being used	1) Check the harness and ensure continuity of the coils & wires are good and connected to the Valve(s) securely 2) If the wiring is pinned out correctly and the alarm is still present replace the controller
215	50	8	8	EVP Driver Short	EVP Proportional Valve is shorted	1) Check for a short or low impedance between Neg- and the the coil. 2) Confirm the Parameter setting is "Present" in "Set Options" 3) Replace the controller
217	56	7	7	Pump I No Zero	When the pump motor is idle there is a feed back current from the controller that is out of range	1) Replace the controller
218	67	8	4	Sens MOT TEMP KO	The motor temperature sensor, related wiring or controller has a problem	1) Check the wiring continuity of the Thermal sensor 2) Check the resistance of the Thermal Sensor 580Ω 3) Turn off the motor temperature detection in the controller and see if the Alarm is still present, if it is replace the controller
219	98	6	3	PEV Not Ok	The Positive voltage signal to the Valve is not good, it is usually due to under voltage.	1) Check the Positive voltage at the valve
220	24	8	2	Key Off Shorted	The controller detects a low level of Key Off signal during start up self check	1) Key input is below allowable voltage, check switch & wiring 2) Check the connections of the Power cables to the controller(s) and Line contactor 3) If no voltage is present when the Key switch is turned on, it could be a controller issue
222	68	4	3	Smart Driver KO	The built in Smart driver is open and not able to provide a Positive+ signal to the brake	1) Check the harness for shorts or opens CAN#2 to Batt - 2) Disconnect the wires to the connector if the alarm is still present replace the controller
223	76	1	2	Coil Short MC-EB	The Controller detects either the Electric Brake or Line Contactor is shorted	1) Check the resistance of the two coils EB 20 Ω / LC 55 Ω ensure they are not shorted or open 2) Check the continuity of the related wiring 3) Replace the controller
224	25	7	6	Waiting For Node	A controller is waiting for a message from one of the other controllers via the CAN	1) Check the CAN wires between the controllers, display and handset 2) Check the power supply for the controllers & display 3) Replace the controller
226	85	2	1	VACC out of Range	The voltage output of the Accellerator / VACC is out of range	1) Calibrate the VACC with a Zapi handset 2) Check the output of the VACC in the "TESTER" mode, if not correct replace the VACC
228	51	5	8	Tiller Open	Check the staus of the Tiller & Accellerator	
229	86	2	8	POS EB Shorted	The Positive + output to the brake coil, it is high during start up	1) Check the harness to verify tehre is Positive+ voltage at CAN#2 2) Disconnect the wire to the connector if the alarm is still present replace the controller
230	77	10	2	Tiller Error	Mismatch between the H&S input and Tiller input	1) Check the harness and CAN#1 To CAN#29 with a VOM 2) If the inputs are correct replace the controller
233	88	5	5	Power MOS Short	The controller tests the phases of the transistors prior to the Line contactor pulling in, if the predetermined values are not met this alarm will occur	1) Replace the controller
234	26	6	2	Driver Short EV	The Electric valve driver in the controller is shorted	1) If the circuit is good replace the controller
236	92	6	8	Current Gain	The maximum current test has not been carried out	1) Restart the truck 2) Replace the controller
237	96	5	1	Analog Input	This happens when the A/D conversion of analog input gives a frozen value, on all converted	1) Replace the controller
238	64	9	1	Tiller Error	Ther is a mismatch of the H&S Input & Tiller Input	1) Check the harness on CAN#1 & CAN#2 2) Replace the controller
239	12	8	6	Controller Mismatched	Controller sotware problem	1) Clear the Eprom 2) Replace the Controller

Figure 3-2 Troubleshooting Chart (Traction/Lift Controller) - Continued

Display Alarm	MDI Alarm	Flash 1	Flash 2	Alarm	Description	Diagnostics
240	48	6	6	EVP Diver Open	The EVP drive is not able to close the valve	1) Check the wiring for that circuit 2) Replace the controller
241	49	7	1	Many Pump Reqs	The controller received many inputs at the same time	1) Check the switch's status 2) Check the harness for shorts
242	79	7	2	Pump Inc Start	The controller gets a command prior to the key switch turning on	1) Check the Lift,Tilt,Side shift, Reach Functions
243	90	7	8	Pump VACC Out of Range	The voltage output of the Hydraulic operation is incorrect	1) Check the voltage output of the potentiometer(s) 2) Check the wires from the potentiometer(s) to the controller 3) Replace the accelerator
245	89	6	7	Pump VACC Not ok	The voltage output of the hydraulic potentiometer is incorrect	1) Check the output voltage of the VACC 2) If none check the wiring 3) Replace the VACC
246	42	4	8	Aux Driver Open	The driver for the brake coil is not able to drive the load	1) Replace the controller
247	0	4	7	Data Acquisition	Acquisition of the current gains	1) The alarm should clear when it gets the data
248	22	4	6	No Can Message	It occurs if the controller does not receive a message over the CAN Bus line	1) Check the continuity of the CAN Circuit 2) Disconnect each module to see if the alarm goes away 3) When you isolate which controller / module is bad replace it
249	0	4	5	Check Up needed		1) It is a maintenance reminder to service the truck 2) Replace the controller if you can not clear the alarm
250	61	4	2	Thermic Sensor KO	The temperature sensor inside the controller is defective	1) Replace the controller
251	41	4	1	Wrong Battery	When the key is turned on, the controller checks the battery voltage and verifies it is with in specifications	1) Replace the battery with a good / correct battery 2) Ensure the controller battery type setting is correct
252	23	9	3	Wrong Zero	The voltage of the amplifiers are not with in specification	1) Replace the controller
253	99	2	4	Slip_Profile	It occurs when the controller is turned on and the Eprom memory has failed	1) Restart the truck 2) Save the parameters and clear the Eprom, then install saved parameters 3) Replace the controller
254	40	2	5	Aux Driver Short	The driver for the brake coil is shorted	1) Check if there is a short or a low impedance between NEBCNA#4 and -BATT 2) Check the resistance of the brake coil and related wiring for shorts and or opens 2) The drive circuit is damaged replace the controller

SECTION 4 STEERING SYSTEM

4-1. CONTROL ARM

4-1.1. Steering Control Removal.

1. Engage the emergency power disconnect switch [Figure 4-1](#) and turn off key switch.
2. Remove screw and separate lower cover from the arm rest.
3. Disconnect harness from potentiometer.
4. Remove screw from steering wheel.
5. Remove four screws, four lock washers.
6. Remove potentiometer from control arm.

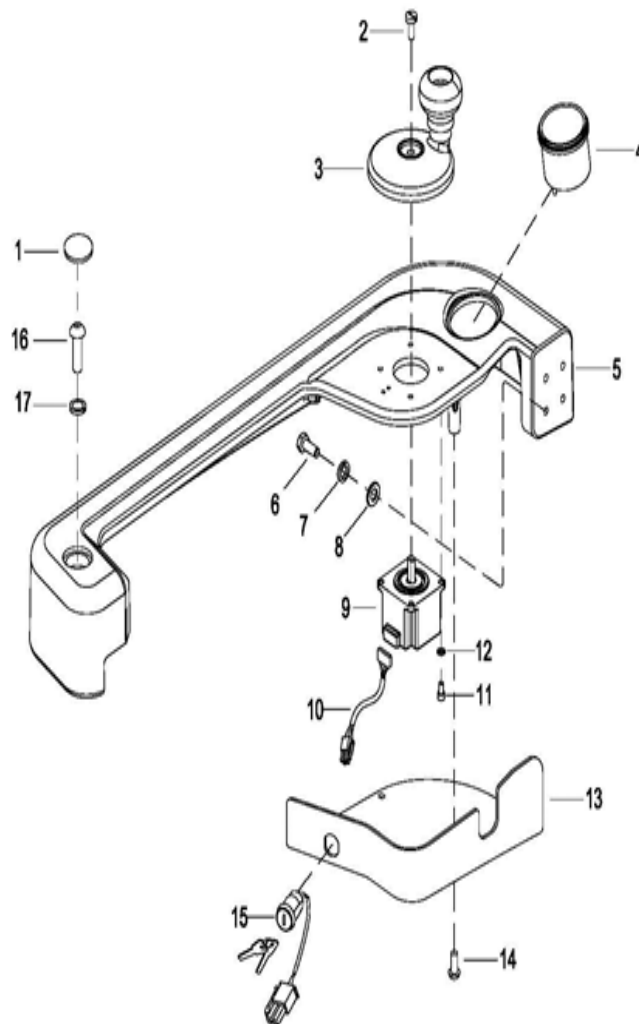

EC_0005

Figure 4-1 Control Arm (Left)

4-1.2. Steering Control Installation.

1. Put the potentiometer in place in the control arm.
2. Secure the potentiometer with four screws and washers.
3. Put the steering wheel in place on the potentiometer and secure with screw.
4. Connect the harness to the potentiometer.
5. Put the lower cover in place and secure with screw.
6. Disengage the emergency power disconnect switch and turn on the key switch.

4-2. FRONT COMPARTMENT COVER

4-2.1. Cover Removal.

1. Engage the emergency power disconnect switch and turn off key switch.
2. Remove five screws that holds the cover down [Figure 4-2](#).
3. Carefully lift cover up and off the vehicle.

4-2.2. Cover Installation.

1. Carefully position cover on the vehicle.
2. Install five screws.
3. Disengage the emergency power disconnect switch and turn on key switch.

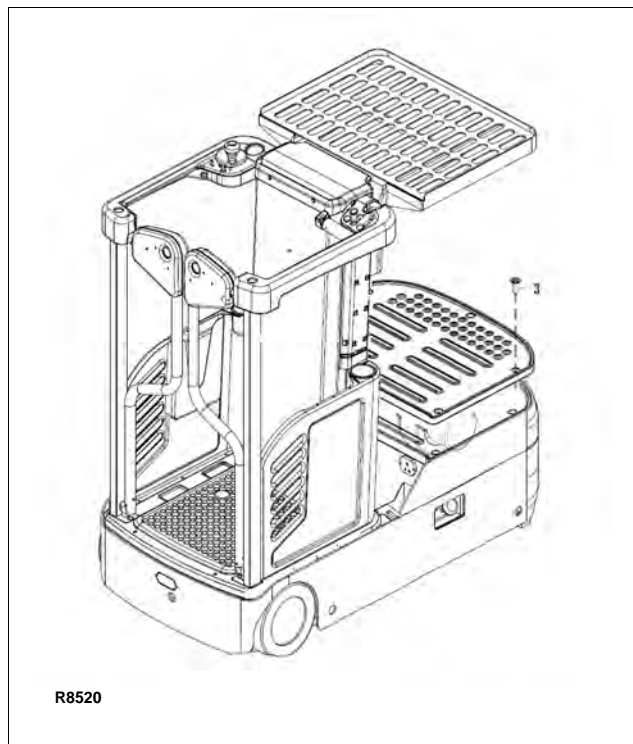

Figure 4-2 Front Compartment Cover

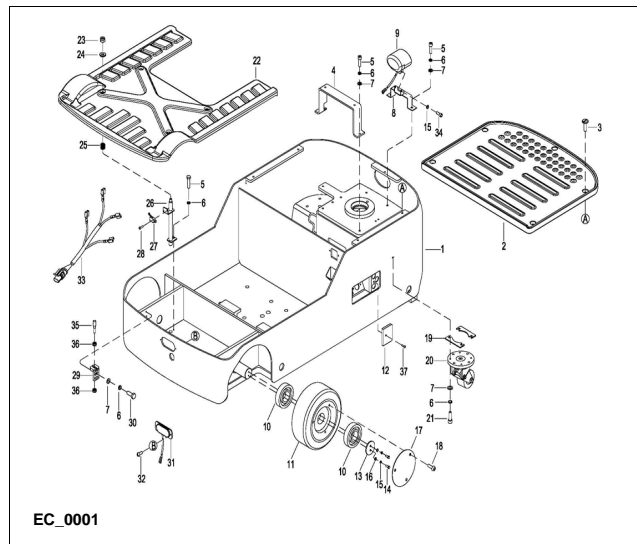

Figure 4-3 Rear Compartment Cover

4-3. REAR COMPARTMENT COVER

4-3.1. Cover Removal.

1. Raise the platform high enough to gain access to the rear compartment cover.
2. Engage the emergency power disconnect switch and turn off key switch.
3. Remove the four nuts and washers that holds the cover down [Figure 4-3](#).
4. Carefully lift cover up and off the vehicle.

4-3.2. Cover Installation.

1. Raise the platform high enough to gain access to the area under the platform
2. Engage the emergency power disconnect switch and turn off key switch.
3. Carefully position cover on the vehicle.
4. Install the four nuts and washers that holds the cover down.
5. Disengage the emergency power disconnect switch and turn on key switch.
6. Lower the platform.

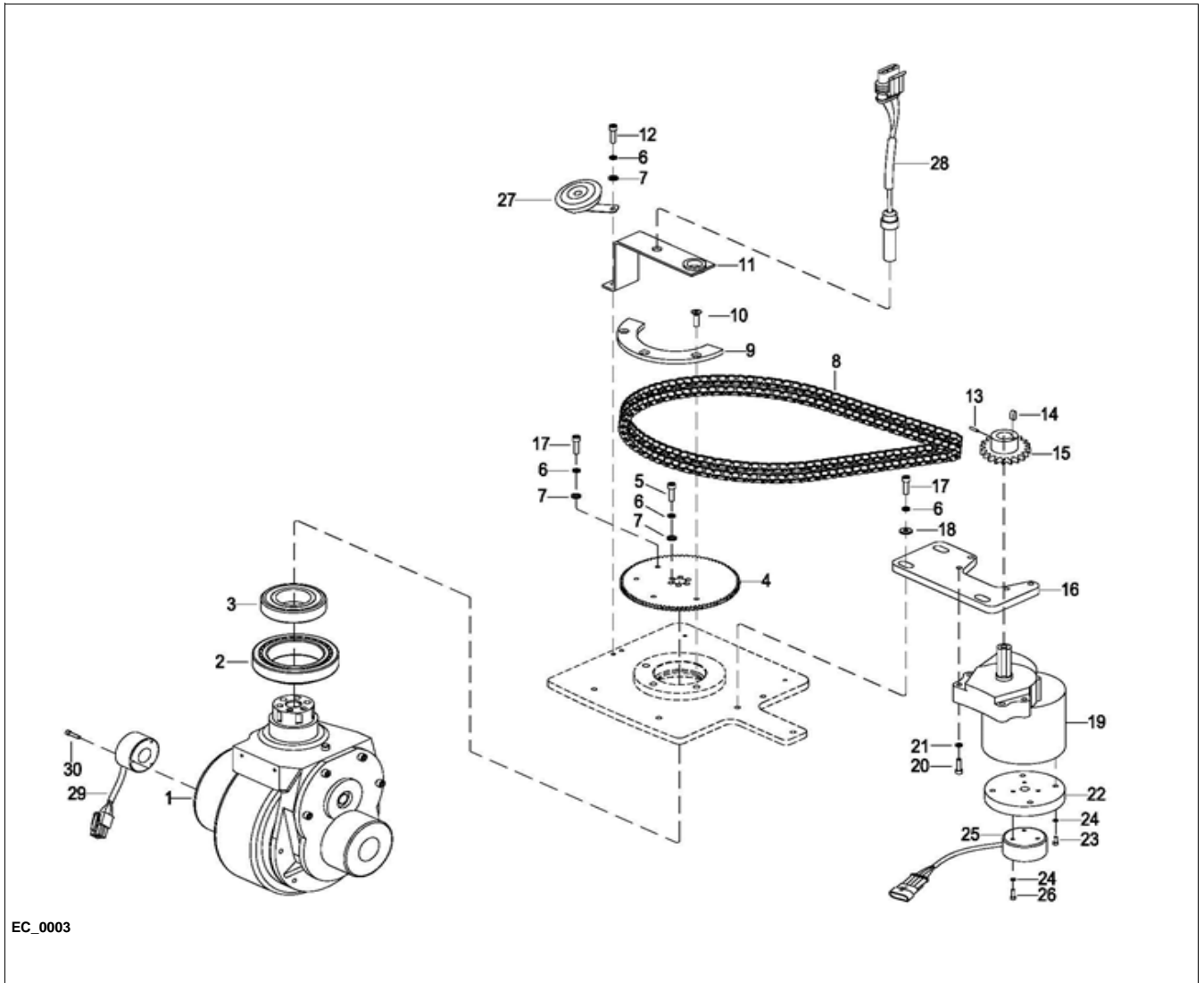

EC_0003

Figure 4-4 Drive System

4-4. STEERING MOTOR

4-4.1. Motor Removal.

1. Engage the emergency power disconnect switch and turn off key switch.
2. Remove the compartment cover as described in paragraph 4-2.1.
3. Disconnect harness and cables from the steering motor.
4. Remove four screws, flat washers and lock washers that secures the steering motor bracket and steering motor to the frame of the vehicle.
5. Remove the steering motor and bracket from the top of the vehicle.
6. Remove four screws, flat washers and lock washers that secures the steering motor to the bracket.

7. Remove the screw and key from the chain gear and then remove the chain gear from the steering motor.

4-4.2. Motor Installation.

1. Secure the chain gear to the steering motor with the key and screw
2. Secure the steering motor to the bracket with four screws, flat washers and lock washers.
3. Put the steering motor with bracket in from the top and secure it with four screws, flat washers and lock washers
4. Reconnect the harness and cables.
5. Install the compartment cover as described in paragraph 4-2.2.
6. Disengage the emergency power disconnect switch and turn on the key switch.

NOTES

SECTION 5 BRAKE SERVICING

5-1. BRAKES.

The brake system consists of a drive motor mounted brake. This brake is spring applied and electrically released. [Figure 5-1](#)

5-1.1. Brake Assembly Replacement

1. Engage the emergency power disconnect switch and turn off key switch.
2. Block load wheels.
3. Remove the compartment cover as described in paragraph [4-2.1](#).
4. Disconnect electric brake from harness.
5. Remove the mounting screws and brake.
6. Place the new brake into position and secure with the mounting screws.
7. Reconnect electric brake to harness.
8. Install the cover as described in paragraph [4-2.2](#).
9. Remove load wheel blocks and check operation.
10. Disengage the emergency power disconnect switch and turn on key switch.

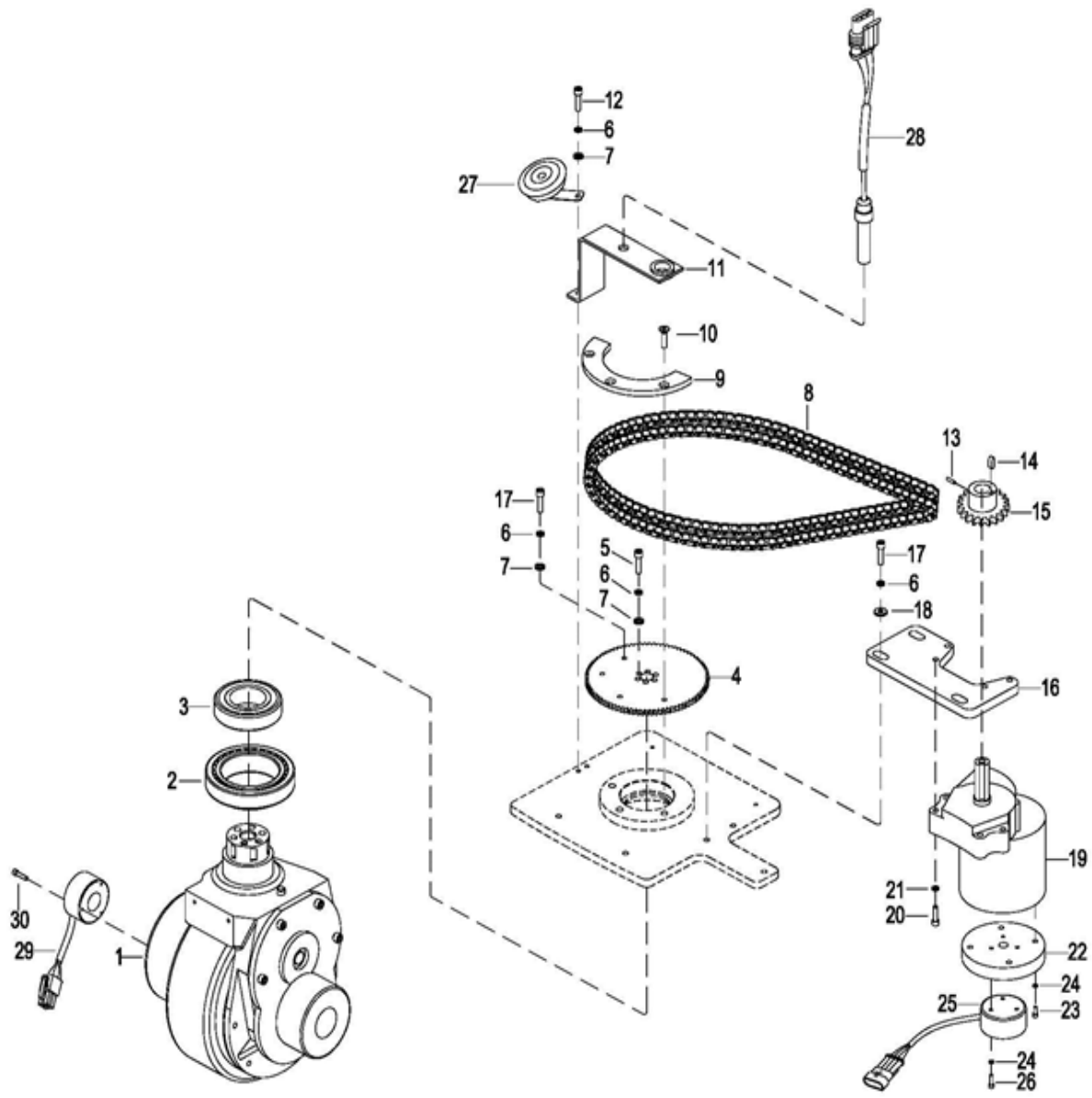

EC_0003

Figure 5-1 Drive System

SECTION 6 TRANSMISSION, DRIVE WHEEL, LOAD WHEEL, CASTERS

6-1. TRANSMISSION AND DRIVE MOTOR.

1. Engage the emergency power disconnect switch and turn off key switch.
2. Remove the compartment cover as described in paragraph 4-2.1.
3. Remove the steering motor as described in paragraph 4-4.1.
4. Raise the vehicle off the ground to provide clearance for drive assembly out the bottom. Securely block the vehicle to prevent movement.
5. Disconnect electric brake from harness.
6. Disconnect cables from drive motor.
7. Support the drive assembly (Figure 6-1) and remove six screws, six washers and flat washers.
8. Lower the drive assembly out the bottom of the vehicle.
9. Install new drive assembly by reversing the steps above.

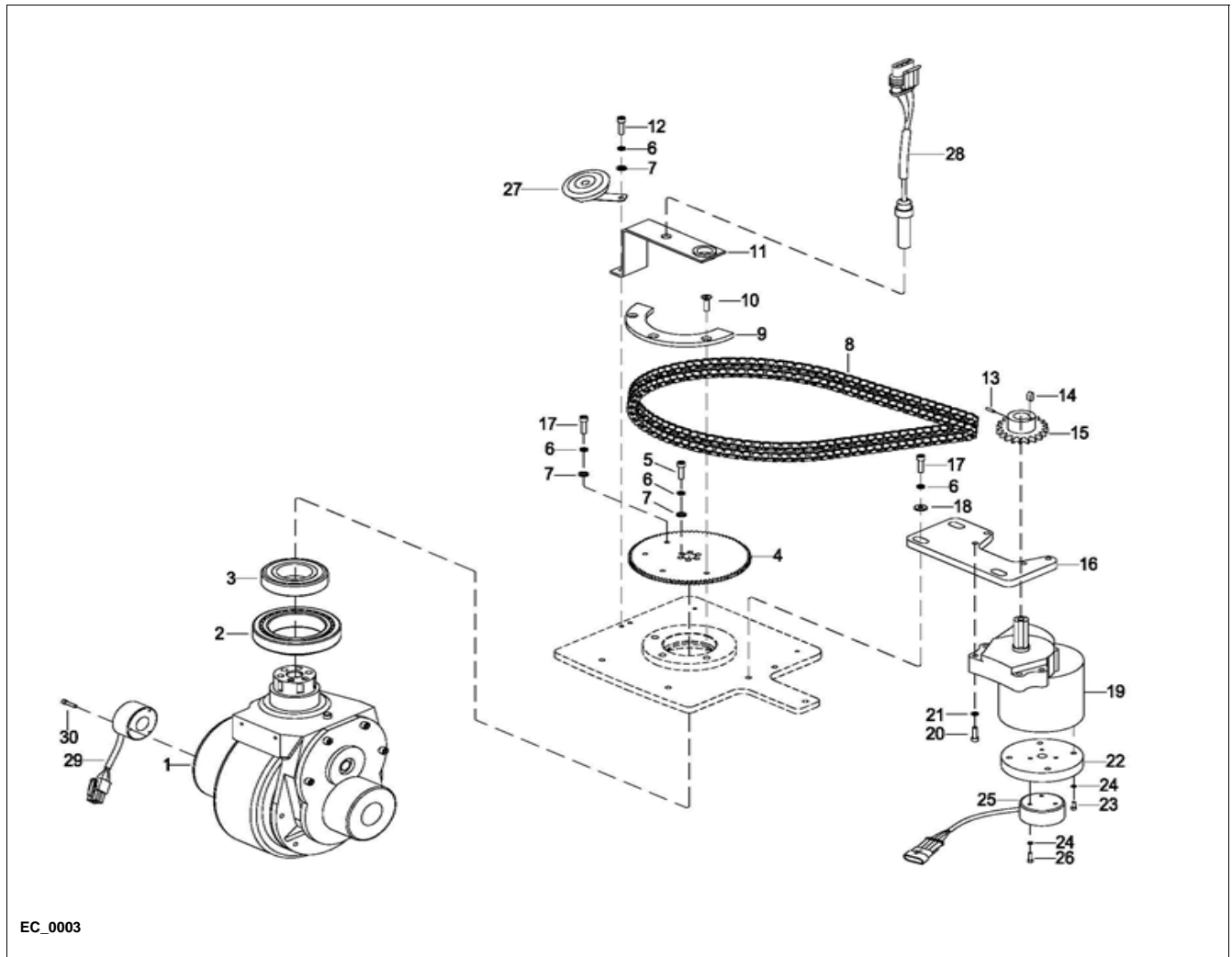

Figure 6-1 Drive System

6-2. LOAD WHEEL.

6-2.1. Removal

1. Engage the emergency power disconnect switch and turn off key switch.
2. Block the drive wheel to prevent the vehicle from rolling.
3. Jack up the vehicle to raise the load wheels off the floor. Securely block the vehicle in the raised position by positioning supports under both fork tips.
4. Remove three screws and cover.
5. Remove two bolts, two lock washers and two flat washers.
6. Remove the load wheel.
7. Remove bearings from load wheel.
8. Inspect bearings and replace if necessary.

6-2.2. Installation

1. Pack bearings with grease.
1. Reassemble bearings in load wheel.
2. Position load wheel on the axle and install two bolts, two lock washers and two flat washers.
3. Install cover and secure with three screws.
4. Remove the blocking from under the vehicle and lower it to the ground.
5. Disengage the emergency power disconnect switch and turn on key switch.

6-3. DRIVE WHEEL.

1. Engage the emergency power disconnect switch and turn off key switch.
2. Jack up the vehicle to gain access to the drive wheel; then securely block the vehicle to prevent movement.
3. Dismantle the motor cable mounting base and remove the motor cables.
4. Loosen the six allen screws and tap off the drive wheel from the drive assembly.
5. Install new drive wheel in reverse order of removal.

6-4. CASTER.

1. Engage the emergency power disconnect switch and turn off key switch.
2. Jack up the vehicle to gain access to the caster; then securely block the vehicle to prevent movement.
3. Remove four screws, four lock washers and four flat washers.
4. Remove caster.
5. Install new caster in reverse order of removal.

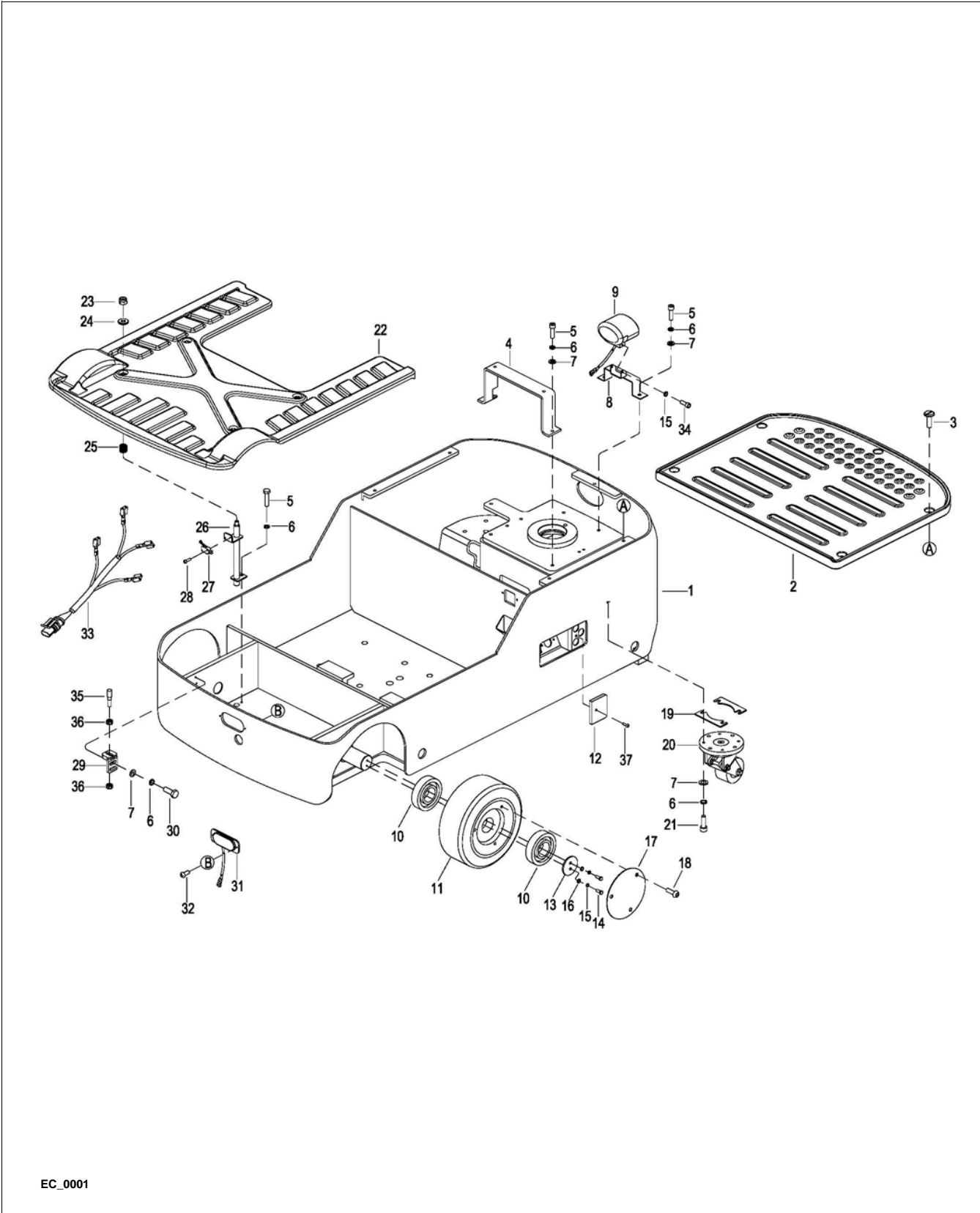

EC_0001

Figure 6-2 Frame

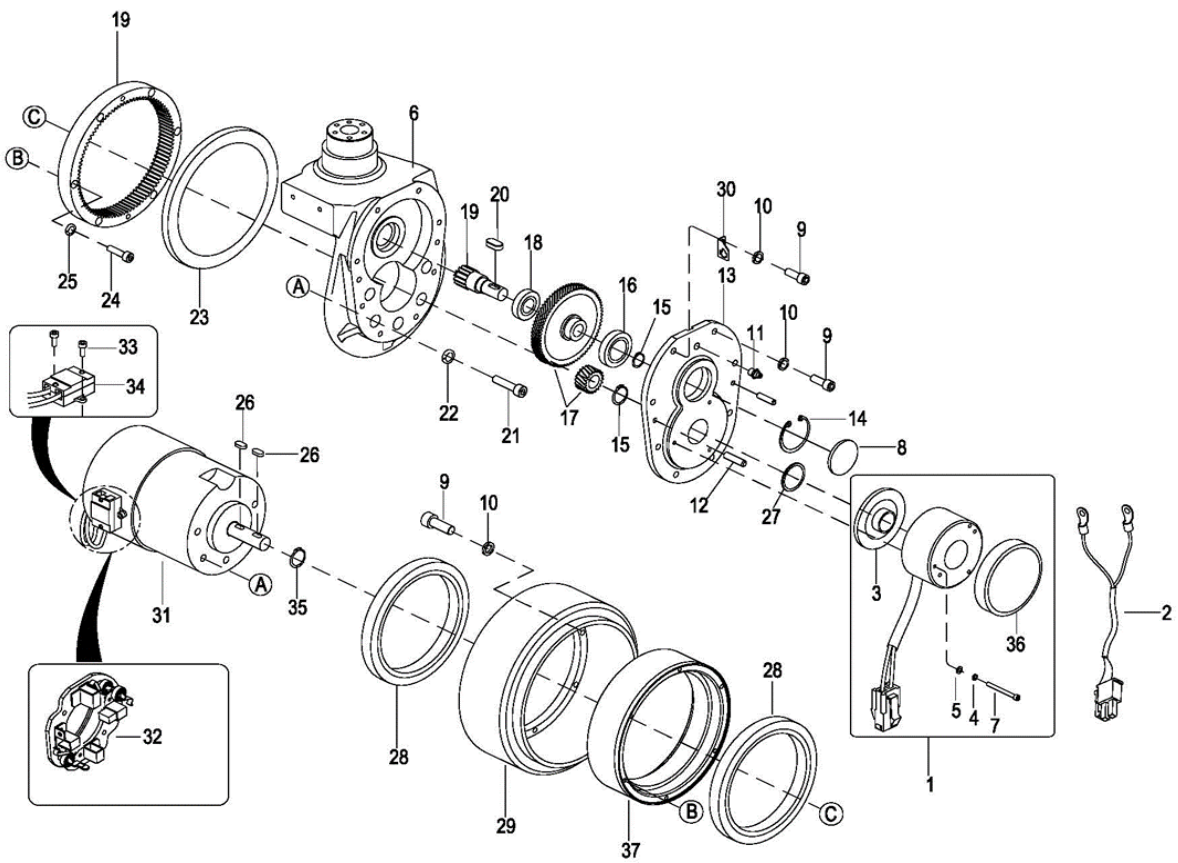

EC_0004

Figure 6-3 Transmission, Motor & Brake Assembly

SECTION 7 ELEVATION SYSTEM SERVICING

7-1. GENERAL.

The elevation system includes the outer mast, inner mast, lift linkage, drag chains, lift chains, lift cylinder and ram head.

7-2. LIFT CHAIN LENGTH ADJUSTMENT.

1. Fully lower the Platform (Figure 7-4).
2. Engage the emergency power disconnect switch and turn off key switch.

WARNING: Before attempting any adjustment, make certain power is disconnected.

3. Loosen jam nut (Figure 7-1) to allow for adjustment.
4. Break the lower jam nut free from the top nut.
5. Take up slack in the lift chain with top nut.
6. Align anchor so the clevis pin is parallel to the mast.
7. Ensure the chain slack actuators are not closing the switch.

CAUTION: At least 3 full threads must be present below lower nut after adjustment.

8. Tighten jam nuts securely while maintaining alignment of clevis pin.
9. Disengage the emergency power disconnect switch and turn on key switch.
10. Test chain by operating Platform. If slack is still apparent, repeat above procedure.

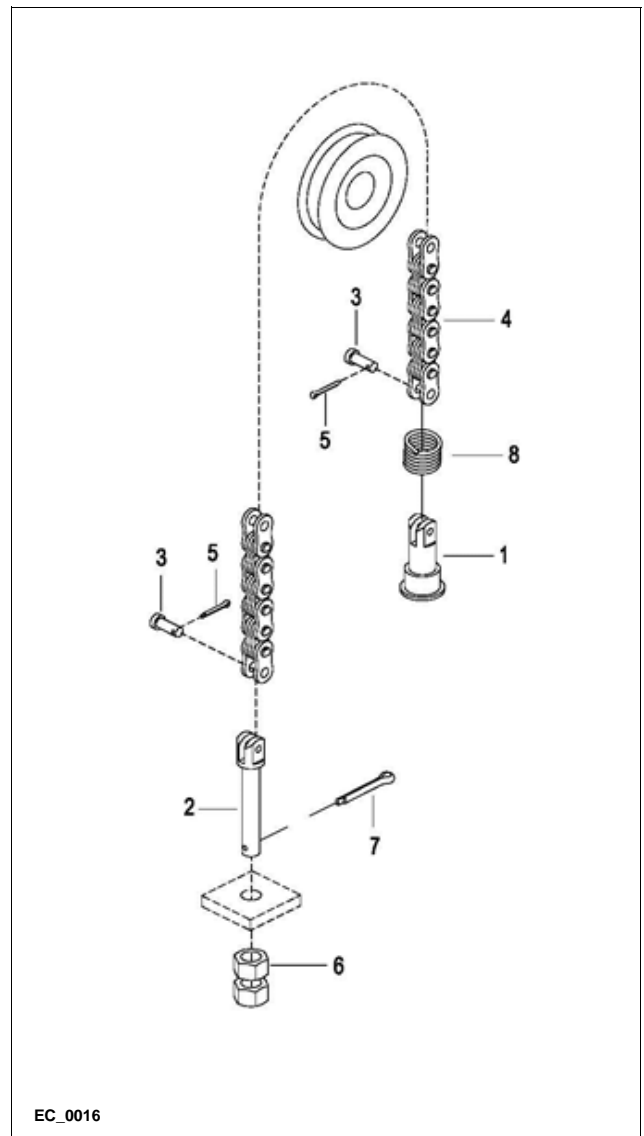

Figure 7-1 Chain Assembly

7-3. LIFT CHAIN WEAR INSPECTION.

The lift chain should be replaced when it is worn enough to increase its length by 3% or more.

To make this determination proceed as follows.

Using a section of chain that sees the most frequent operation over the chain sheaves, isolate a vertical portion under tension from the weight of carriage and forks.

Measure the distance between pin centers on 20 vertical links. If the section measures 12.88" or more, the chain should be replaced.

New chain anchor pins should be installed when chains are replaced. Never replace a partial section of chain and never repair chain. Refer to paragraph 7-4. when installing new chain.

7-4. LIFT CHAIN REPLACEMENT.

7-4.1. Three Stage Mast

7-4.1.1. Mast Lifting Chain

1. With the vehicle wheels securely blocked, raise the inner mast ([Figure 7-3](#)) approximately three feet and position blocks or strong supports under the inner mast.

2. Lower inner mast onto the support. Check that arrangement is secure before proceeding.
3. Engage the emergency power disconnect switch and turn off key switch.

WARNING: Before attempting any replacement, make certain power is disconnected.

4. Remove cotter pin, clevis pin and anchor connecting chain to inner mast.
5. Remove cotter pin and clevis pin connecting chain to adjusting screw at the outer mast.
6. Remove chain from sheave.
7. Position new chain on sheave.
8. Secure chain to outer mast with adjusting screw clevis pin and cotter pin.
9. Connect the opposite end of chain to the inner mast with anchor, clevis pin and cotter pin.
10. Adjust the chains according to [paragraph 7-2](#).
11. Disengage the emergency power disconnect switch and turn on key switch.

7-5. LIFT CYLINDERS.

NOTE: Removal and repair of lift cylinders are covered in [SECTION 8](#).

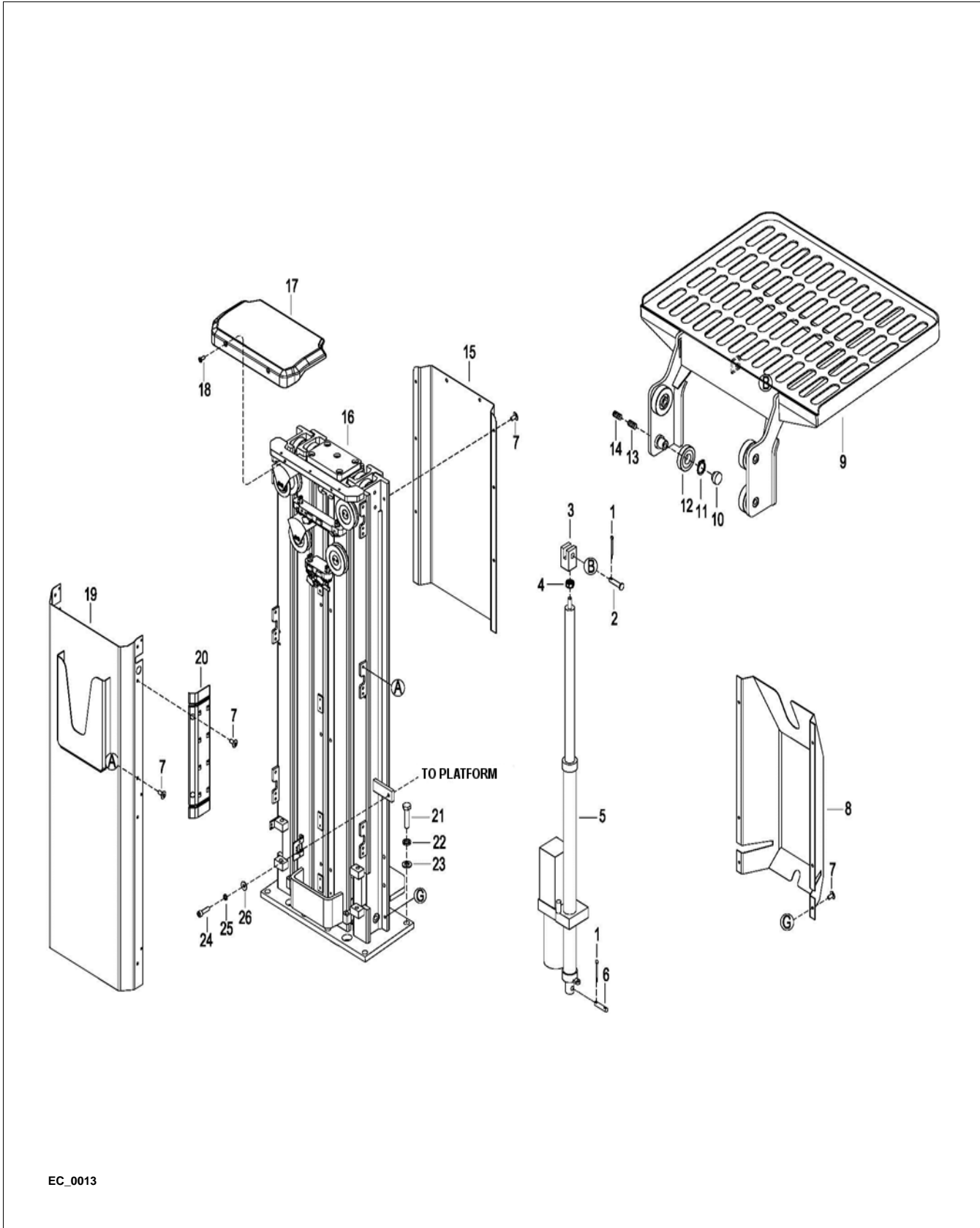

EC_0013

Figure 7-2 Elevation System - Overview

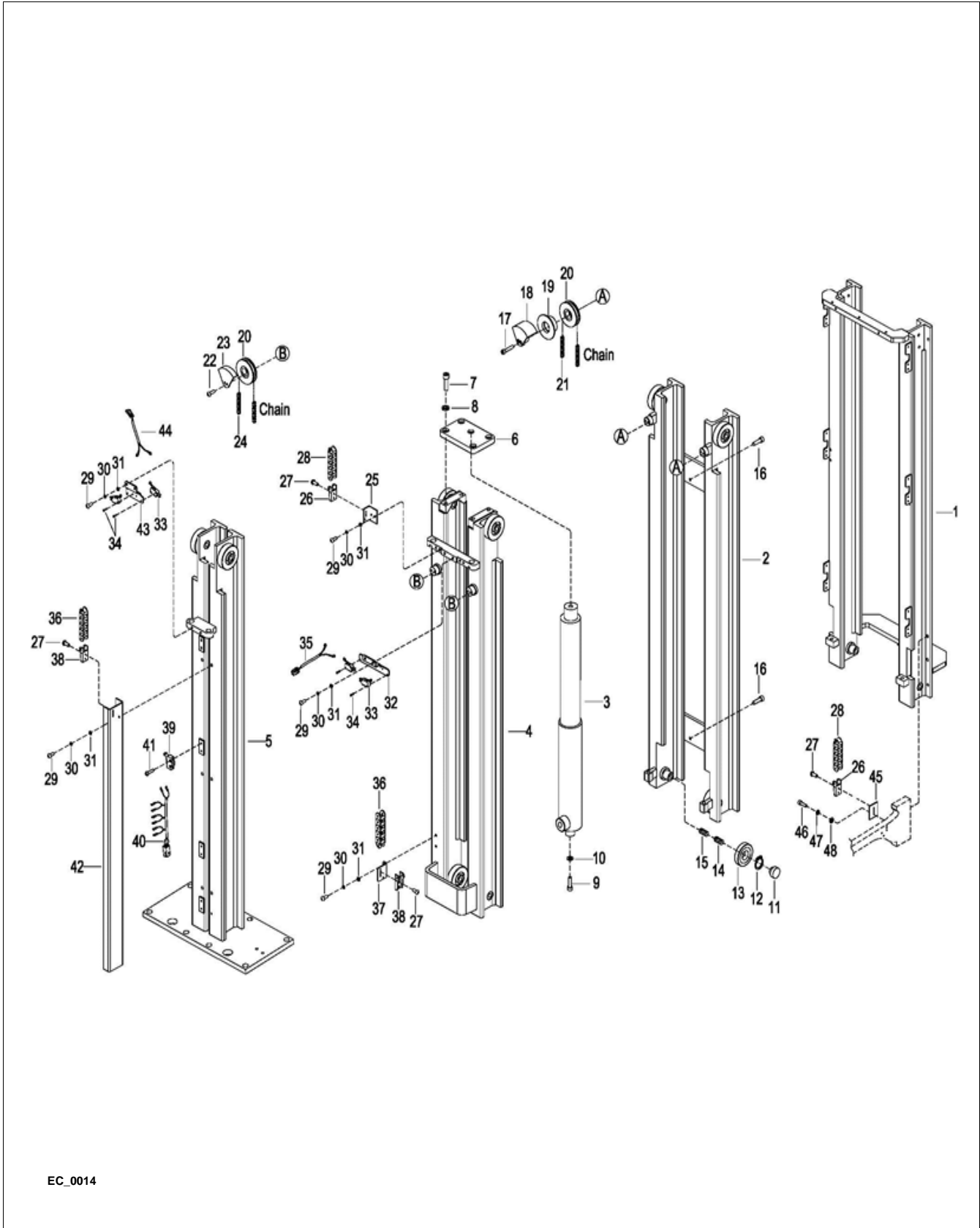

EC_0014

Figure 7-3 Elevation System - Breakdown

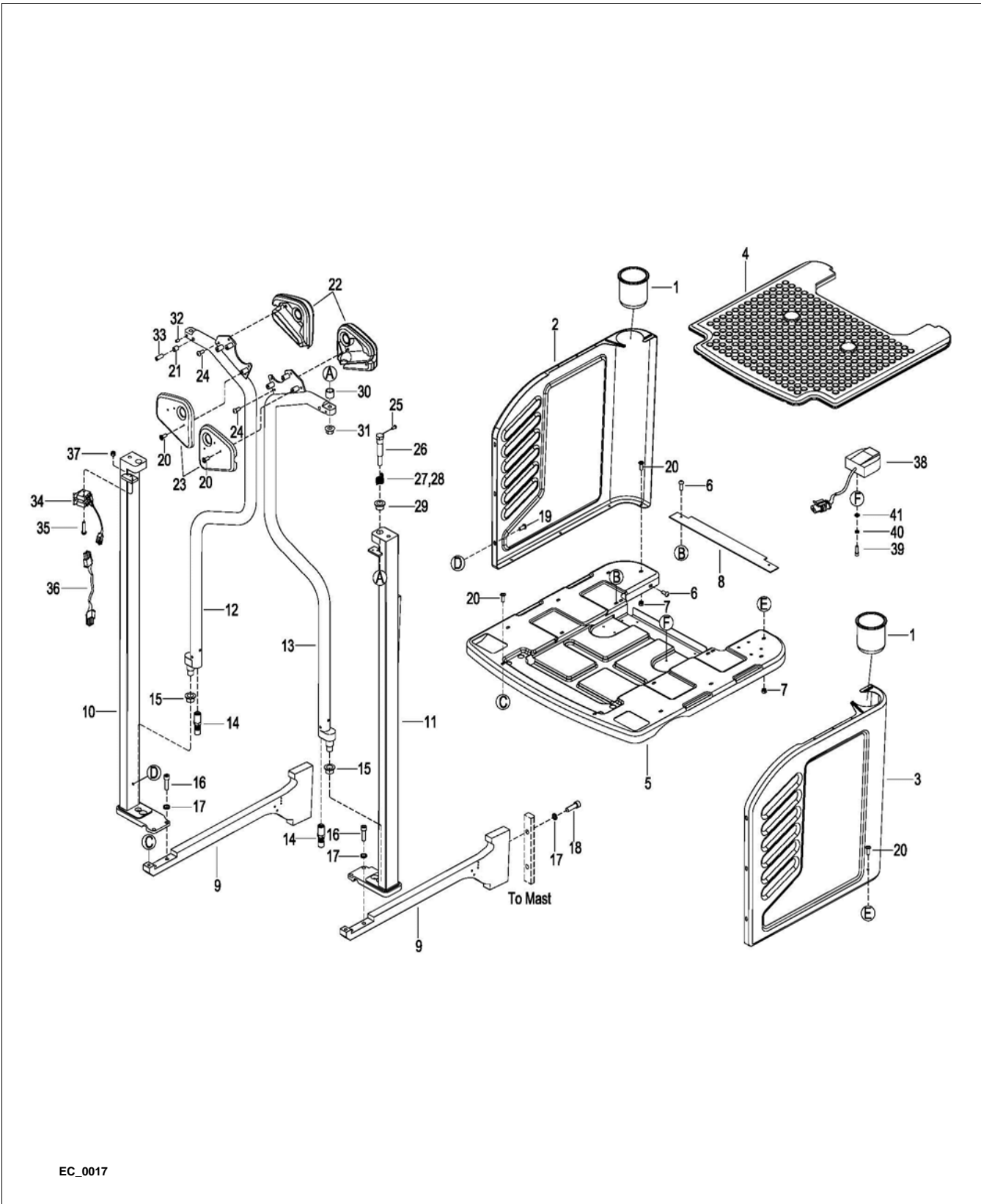

EC_0017

Figure 7-4 Platform

SECTION 8 HYDRAULIC SYSTEM SERVICING

8-1. LINES AND FITTINGS

WARNING: When the platform is raised, pressure exists in the hydraulic system lines and fittings. To ensure release of pressure, platform must be fully lowered and the batteries disconnected before performing any maintenance on the hydraulic system.

NOTE: Leaking hydraulic fittings may be remedied by simply tightening fittings. If this does not remedy the leak, the fittings or line must be replaced.

1. Fully lower the platform.
2. Engage the emergency power disconnect switch and turn off key switch.
3. Remove the compartment cover as described in paragraph 4-2.1.

WARNING: Relieve pressure off the system prior to opening any lines.

CAUTION: Hydraulic oil can damage parts. Wipe off any oil immediately. Provide a container under the line or fitting before disconnecting.

4. Refer to [Figure 8-1](#) and remove leaking line or fitting and replace it with a new line or fitting.
5. Check level of hydraulic oil. If required, add hydraulic oil to bring to proper level. Use hydraulic oil listed in [Table 2-2](#).
6. Disengage the emergency power disconnect switch and turn on key switch.
7. Operate the lift and lower buttons to refill the cylinder and lines with hydraulic oil.
8. Check level of hydraulic oil. If required, add hydraulic oil to bring to proper level. Use hydraulic oil listed in [Table 2-2](#).
9. Install the compartment cover as described in paragraph 4-3.2.

8-2. HYDRAULIC PUMP, MOTOR, AND RESERVOIR ASSY

The hydraulic pump/motor assembly can be disassembled and repaired. However, a defective pump, valve or motor requires replacement of that component.

WARNING: When the platform is raised, pressure exists in the hydraulic system lines and fittings. To ensure release of pressure, platform must be fully lowered and the batteries disconnected before performing any maintenance on the hydraulic system.

8-2.1. Removal

1. Fully lower the platform.
2. Engage the emergency power disconnect switch and turn off key switch.
3. Remove the compartment cover as described in paragraph 4-2.1.
4. Tag and disconnect electrical leads from motor and solenoid of pump/motor assembly.

NOTE: The reservoir and tube will be filled with hydraulic oil. Place a container under the pump assembly to catch any hydraulic oil.

5. Disconnect hose from pump/motor assembly.
6. While supporting pump/motor assembly, remove two screws and two lock washers.
7. Remove the pump/motor assembly.
8. Remove the bracket from the pump/motor assembly.
9. Install pump/motor assembly in reverse order of removal.

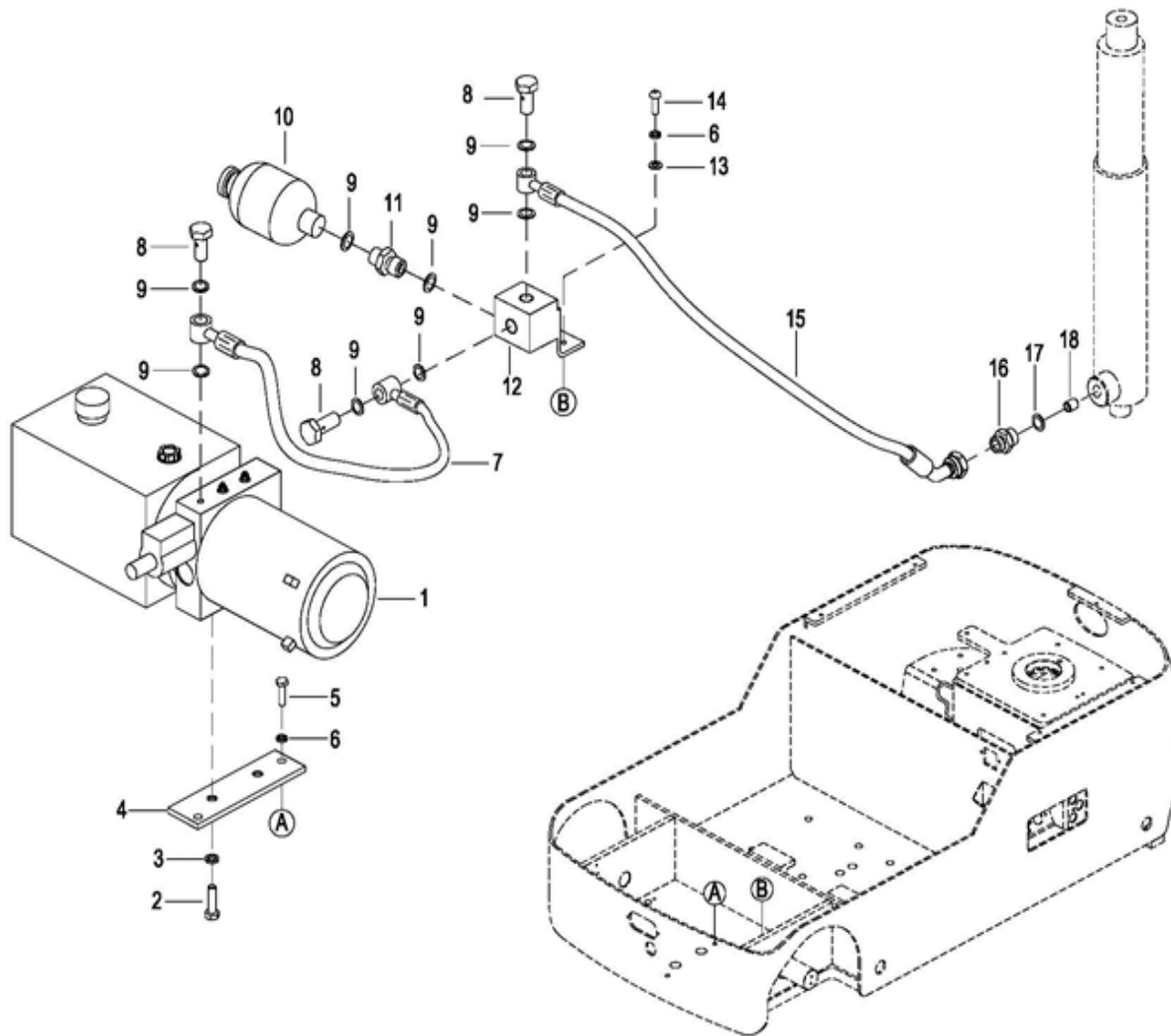

EC_0007

Figure 8-1 Hydraulic System

8-2.2. Installation

1. Install pump/motor assembly as described in paragraph 8-2.1.
2. Reconnect hose to pump/motor assembly.
3. Connect electrical leads to motor and solenoid of pump/motor assembly.
4. Fill the hydraulic reservoir. Use hydraulic oil listed in Table 2-2.
5. Disengage the emergency power disconnect switch and turn on key switch.
6. Operate the lift and lower buttons to refill the cylinder and lines with hydraulic oil.
7. Check level of hydraulic oil. If required, add hydraulic oil to bring to proper level. Use hydraulic oil listed in Table 2-2.
8. Install the compartment cover as described in paragraph 4-3.2.

8-2.3. Disassembly and Reassembly

1. Remove the hydraulic pump/motor assembly as described in paragraph 8-2.1.
2. Refer to Figure 11-8 for disassembly and reassembly.

8-3. LIFT CYLINDER - MAIN

8-3.1. Removal

1. Engage the emergency power disconnect switch and turn off key switch.

WARNING: Relieve pressure off the system prior to opening any lines.

Before attempting any replacement, make certain power is disconnected.

CAUTION: Hydraulic oil can damage parts. Wipe off any oil immediately. Provide a container under the line or fitting before disconnecting.

2. Raise the platform high enough to remove the six screws and remove the front lower cover.
3. Remove eight screws and remove the front upper cover.
4. Remove eight screws and remove the top mast cover.
5. Raise the vehicle high enough from the floor so that you can access the screw that secures the cylinder to the mast. Make sure to securely block the vehicle or use strong supports so that the vehicle won't fall down.
6. Once you have removed the screw from underneath the vehicle lower it to the ground.

WARNING: Support lift cylinder before performing the following steps to prevent cylinder from falling.

7. Remove the five screws and lock washers that holds down the cylinder mount plate at the top of the mast.
8. Carefully raise lift cylinder assembly up and out of vehicle.

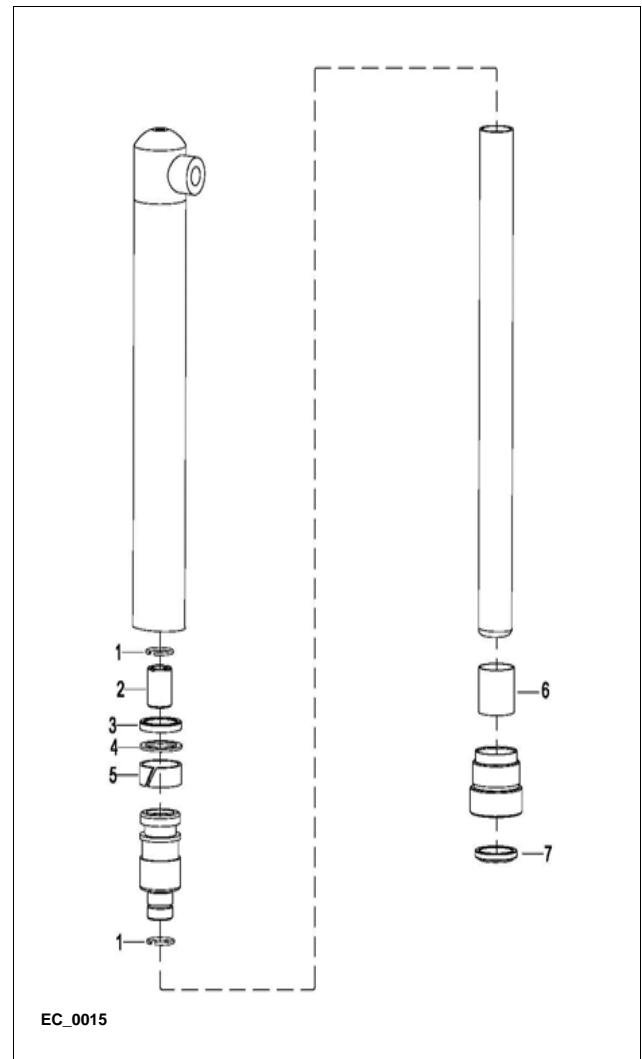

Figure 8-2 Lift Cylinder - Main

8-3.2. Repair

CAUTION: To prevent damage, use proper pipe clamp vise. The cylinder will be distorted if the vise is tightened too much.

1. Secure the lift cylinder in a vise, clamping lightly at the base of the cylinder.
2. Remove gland nut (Figure 8-2).
3. Remove dust seal from gland nut.
4. Pull out piston rod.
5. Remove snap ring and piston from rod.
6. Remove snap rings, seals and backup ring from piston.
7. Coat all parts with hydraulic oil (Table 2-2).
8. For assembly Install in reverse order of removal.

8-3.3. Installation

1. Install lift cylinder assembly in reverse order of removal.

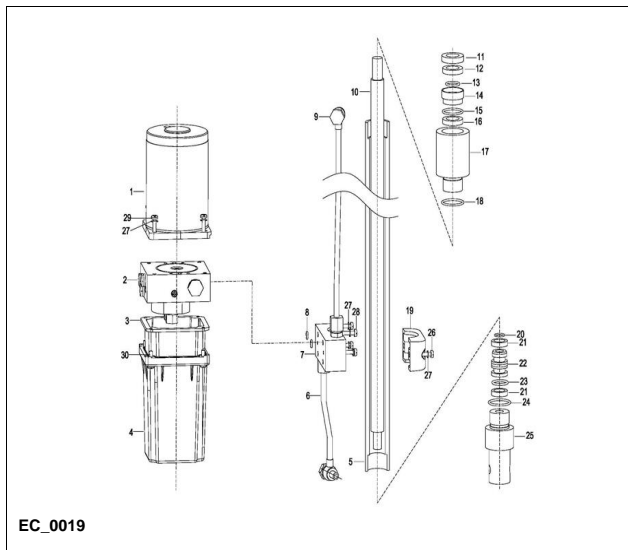

Figure 8-3 Lift Cylinder - Tray

8-4. LIFT CYLINDER - TRAY

8-4.1. Removal

1. Engage the emergency power disconnect switch and turn off key switch.

WARNING: Before attempting any replacement, make certain power is disconnected.

CAUTION: Hydraulic oil can damage parts. Wipe off any oil immediately. Provide a container under the line or fitting before disconnecting from cylinder.

2. Raise the platform high enough to remove the six screws and remove the front lower cover.
3. Remove eight screws and remove the front upper cover.

WARNING: Support cylinder before performing the following steps to prevent cylinder from falling.

4. Remove the cotter pin and shaft from the bottom of the cylinder.
5. Remove the cotter pin and shaft from the top of the cylinder and make sure you support the cylinder so that it does not fall out.
6. Carefully raise lift cylinder assembly up and out of vehicle.

8-4.2. Repair

CAUTION: To prevent damage, use proper pipe clamp vise. The cylinder will be distorted if the vise is tightened too much.

1. Secure the lift cylinder in a vise, clamping lightly at the base of the cylinder.
2. Remove the end cap.
3. Remove the snap ring, dust ring, seal, copper sleeve, seal, oil seal and seal from the end cap.
4. Remove the rod seal, oil seal, piston and rod seal ring from the base.
5. Coat all parts with hydraulic oil (Table 2-2).
6. For assembly Install in reverse order of removal.

8-4.3. Installation

1. Install tray lift cylinder assembly in reverse order of removal.

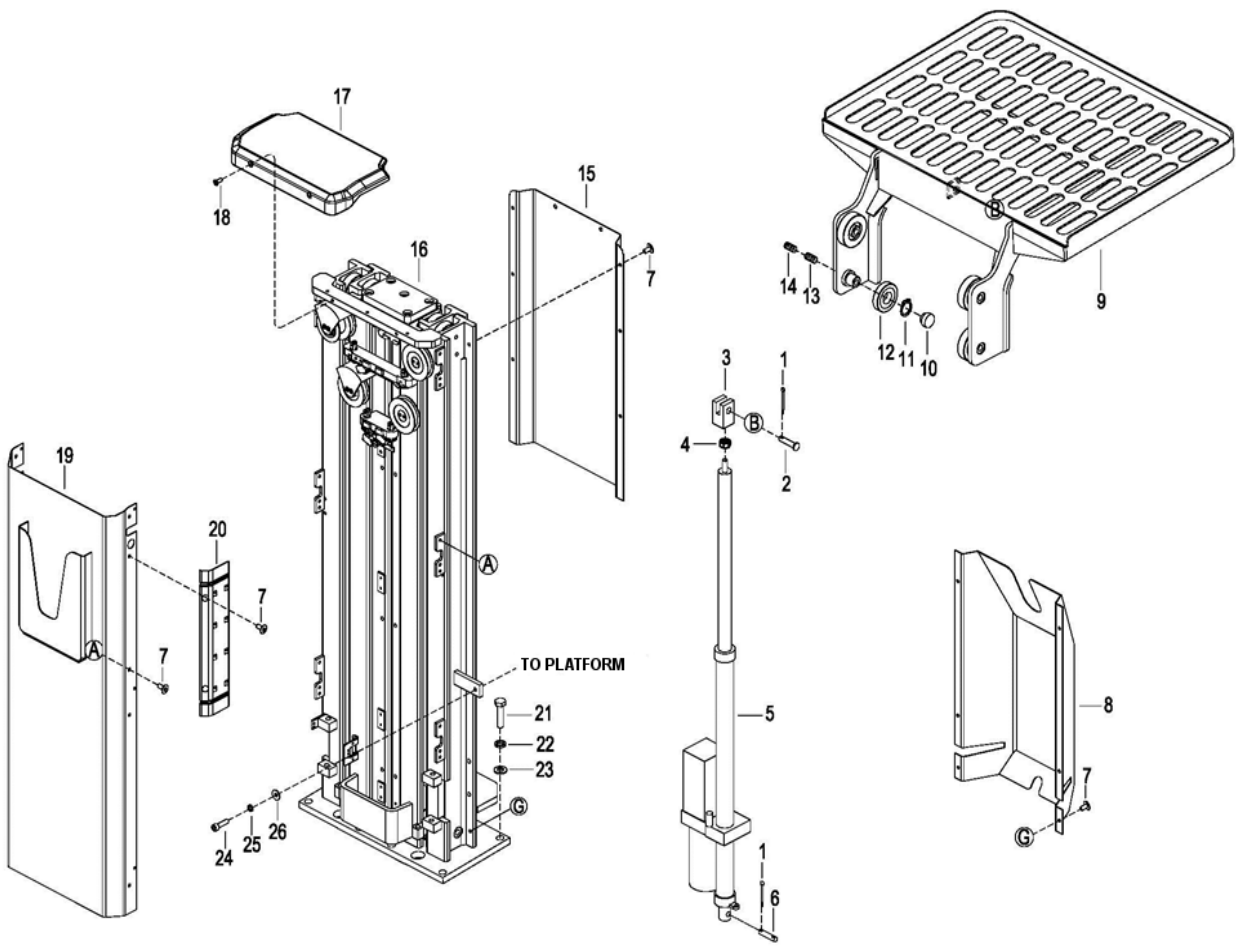

EC_0013

Figure 8-4 Elevation System - Overview

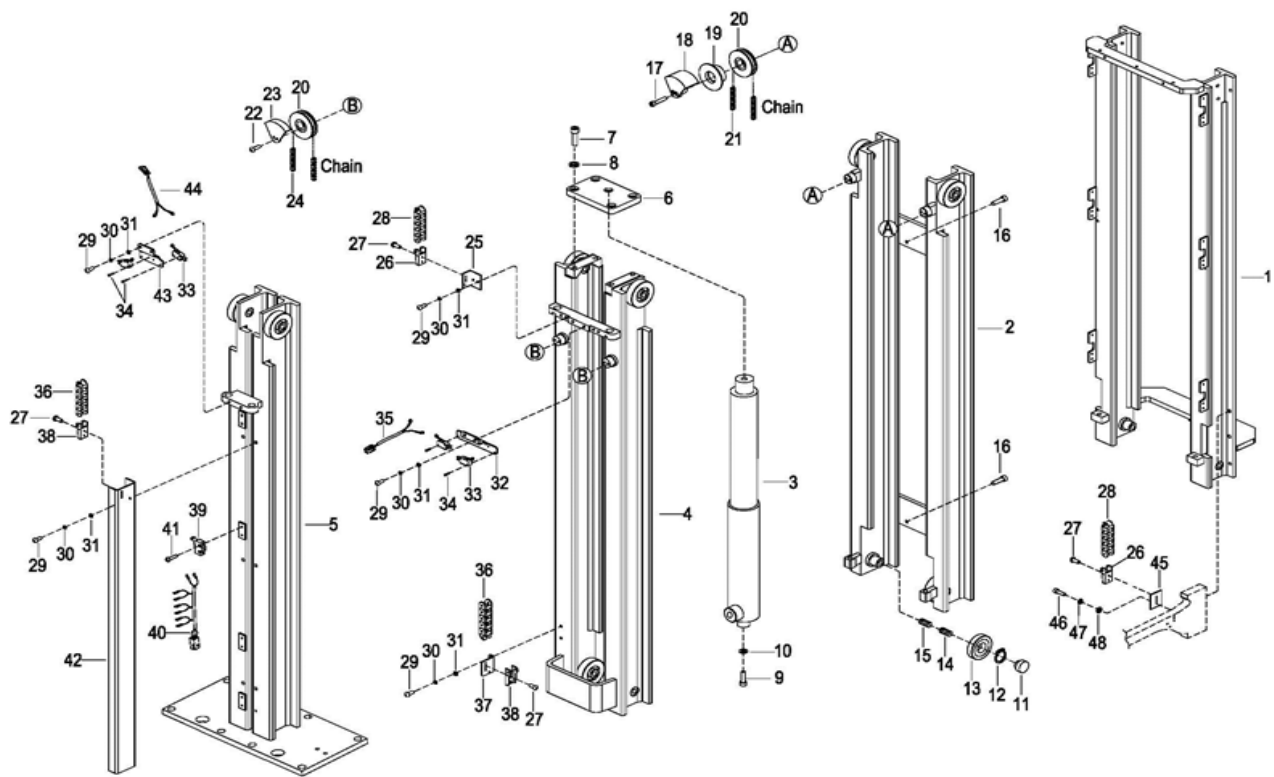

EC_0014

Figure 8-5 Elevation System - Breakdown

SECTION 9 ELECTRICAL COMPONENTS

9-1. ELECTRICAL CONTROL PANEL

9-1.1. Maintenance

NOTE: Erratic operation of the vehicle may be caused by defective controller components. Before removing the electrical panel, perform troubleshooting procedures per [SECTION 3](#), to determine corrective action to be taken.

There are no serviceable parts inside the controller. No attempt should be made to open the controller. Opening the controller may damage it and will void the warranty.

The controller is programmed at the factory specifically for the vehicle model on which it is equipped. It is important to replace the controller with the correct preprogrammed unit to assure proper performance settings intended for that particular vehicle. See [Figure 11-9](#) for the preprogrammed controller number.

It is recommended that the controller exterior be cleaned periodically, and if a hand held programmer is available, this periodic cleaning provides a good opportunity to check the controller's diagnostic history file. It is also recommended that the controller's fault detection circuitry be checked whenever the vehicle is serviced.

9-1.2. Cleaning

1. Engage the emergency power disconnect switch and turn off key switch.
2. Remove the compartment cover as described in paragraph [4-2.1](#).
3. Remove any dirt or corrosion from the bus bar area. The controller should be wiped clean with a moist rag. Allow it to dry before reconnecting the battery.

9-1.3. Panel Removal.

1. Engage the emergency power disconnect switch and turn off key switch.

2. Remove the compartment cover as described in paragraph [4-2.1](#).
3. Tag and disconnect all electrical cables and harness from control panel.
4. Remove four screws, four lock washers, four flat washers and panel.

9-1.4. Panel disassembly.

Refer to [Figure 11-9](#) for the location and identity of the major replacement components mounted on the panel and remove defective parts.

9-1.5. Panel Installation.

1. Position panel and secure with four screws, four lock washers, four flat washers.
2. Connect all electrical cables and harness to the control panel as noted during removal.
3. Install compartment covers as described in paragraph [4-2.2](#).
4. Disengage the emergency power disconnect switch and turn on key switch.

9-2. HORN REPLACEMENT.

1. Engage the emergency power disconnect switch and turn off key switch.
2. Remove the compartment cover as described in paragraph [4-2.1](#).
3. Tag and disconnect harness from horn.
4. Remove screw, lock washer, flat washer and horn.
5. Install horn and secure with screw, lock washer, flat washer.
6. Reconnect harness to horn.
7. Install compartment covers as described in paragraph [4-2.2](#).
8. Disengage the emergency power disconnect switch and turn on key switch.

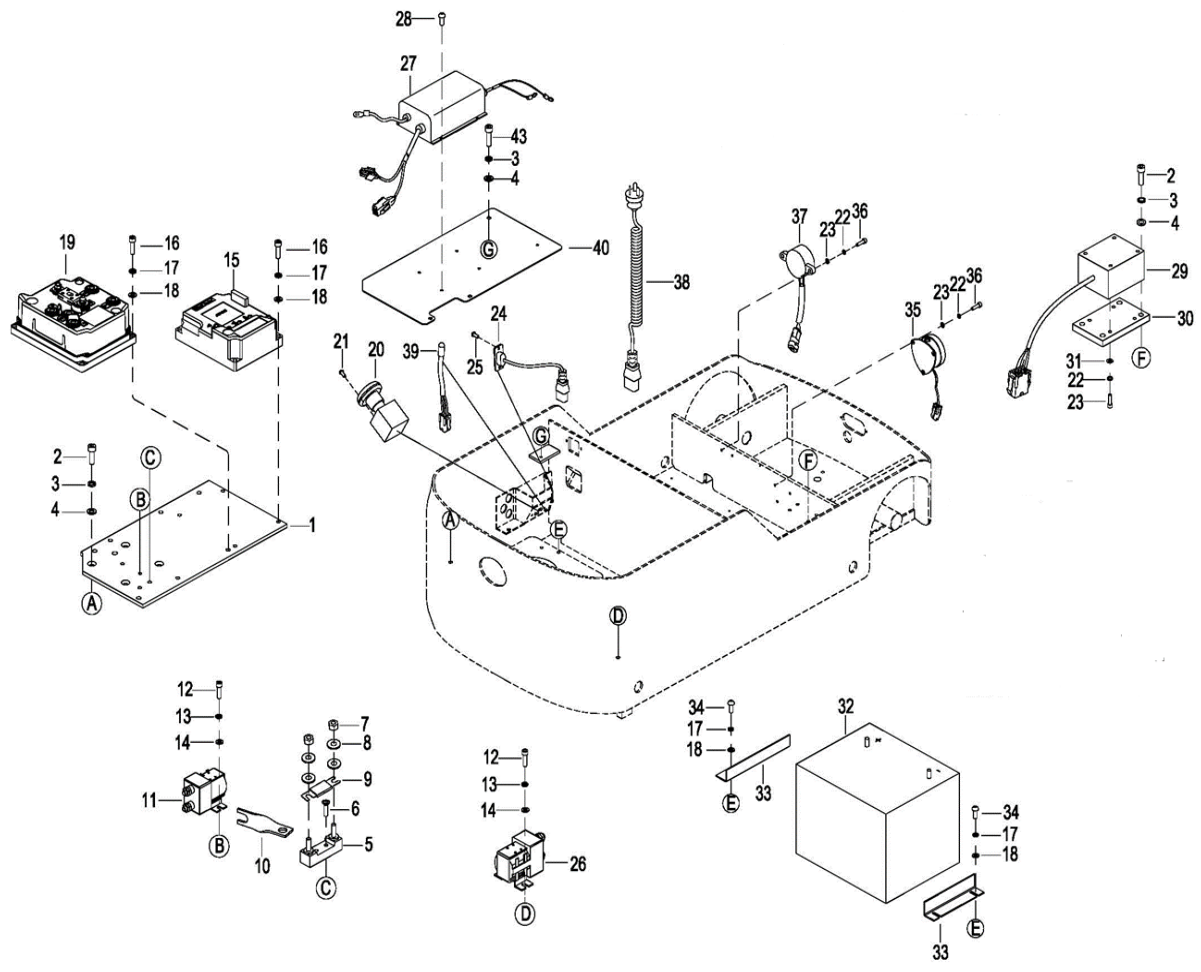

EC_0009

Figure 9-1 Electrical System

9-3. LOWERING BUZZER REPLACEMENT.

1. Engage the emergency power disconnect switch and turn off key switch.
2. Remove the compartment cover as described in paragraph 4-3.1.
3. Label and disconnect harness from buzzer.
4. Remove screw, lock washer, flat washer and buzzer.
5. Install new buzzer and secure with screw, lock washer, flat washer.
6. Reconnect harness to buzzer.
7. Install compartment covers as described in paragraph 4-3.2.
8. Disengage the emergency power disconnect switch and turn on key switch.

9-4. LEVEL SENSOR BUZZER REPLACEMENT.

1. Engage the emergency power disconnect switch and turn off key switch.
2. Remove the compartment cover as described in paragraph 4-3.1.
3. Label and disconnect harness from buzzer.
4. Remove screw, lock washer, flat washer and buzzer.
5. Install new buzzer and secure with screw, lock washer, flat washer.
6. Reconnect harness to buzzer.
7. Install compartment covers as described in paragraph 4-3.2.
8. Disengage the emergency power disconnect switch and turn on key switch.

9-5. LEVEL SENSOR REPLACEMENT.

1. Engage the emergency power disconnect switch and turn off key switch.
2. Remove the compartment cover as described in paragraph 4-3.1.
3. Label and disconnect harness from sensor.
4. Remove four screws, four lock washers and four flat washers.
5. Remove mounting plate with sensor.
6. Remove four screws, four lock washers and four flat washers and separate sensor from mounting plate.

7. Position new sensor on mounting plate and secure with four screws.
8. Install mounting plate with sensor and secure with four screws, four lock washers and four flat washers.
9. Reconnect harness to sensor.
10. Install compartment covers as described in paragraph 4-3.2.
11. Disengage the emergency power disconnect switch and turn on key switch

9-6. WARNING LIGHT REPLACEMENT.

1. Engage the emergency power disconnect switch and turn off key switch.
2. Remove the compartment cover as described in paragraph 4-3.1.
3. Label and disconnect harness from warning light.
4. Remove three screws and warning light.
5. Install new warning light and secure with three screws.
6. Reconnect harness to warning light.
7. Install compartment covers as described in paragraph 4-3.2.
8. Disengage the emergency power disconnect switch and turn on key switch.

9-7. BLUE LIGHT REPLACEMENT.

1. Engage the emergency power disconnect switch and turn off key switch.
2. Remove the compartment cover as described in paragraph 4-2.1.
3. Label and disconnect harness from blue light.
4. Remove two screws, lock washers, flat washers and blue light.
5. Install new light and secure with two screws, lock washers and flat washers.
6. Reconnect harness to blue light.
7. Install compartment covers as described in paragraph 4-2.2.
8. Disengage the emergency power disconnect switch and turn on key switch.

9-8. BATTERY REPLACEMENT.

Replace the battery as described in paragraph 2-7.

9-9. BATTERY CHARGER.

9-9.1. Removal.

1. Engage the emergency power disconnect switch and turn off key switch.
2. Remove the compartment cover as described in paragraph 4-2.1.
3. You will need to remove the Control Panel first. Remove four screws. Tag and disconnect all electrical cables and harness from control panel.
4. Remove four screws, four lock washers, four flat washers and panel.

5. Remove the Control Panel Assembly out of the way.
6. Disconnect cables and harnesses from charger.
7. Remove the charger mounting screws and charger.

9-9.2. Installation.

1. Position the new charger in frame and secure with four screws.
2. Reconnect cables and harnesses to the charger.
3. Install compartment covers as described in paragraph 4-2.2.
4. Disengage the emergency power disconnect switch and turn on key switch.

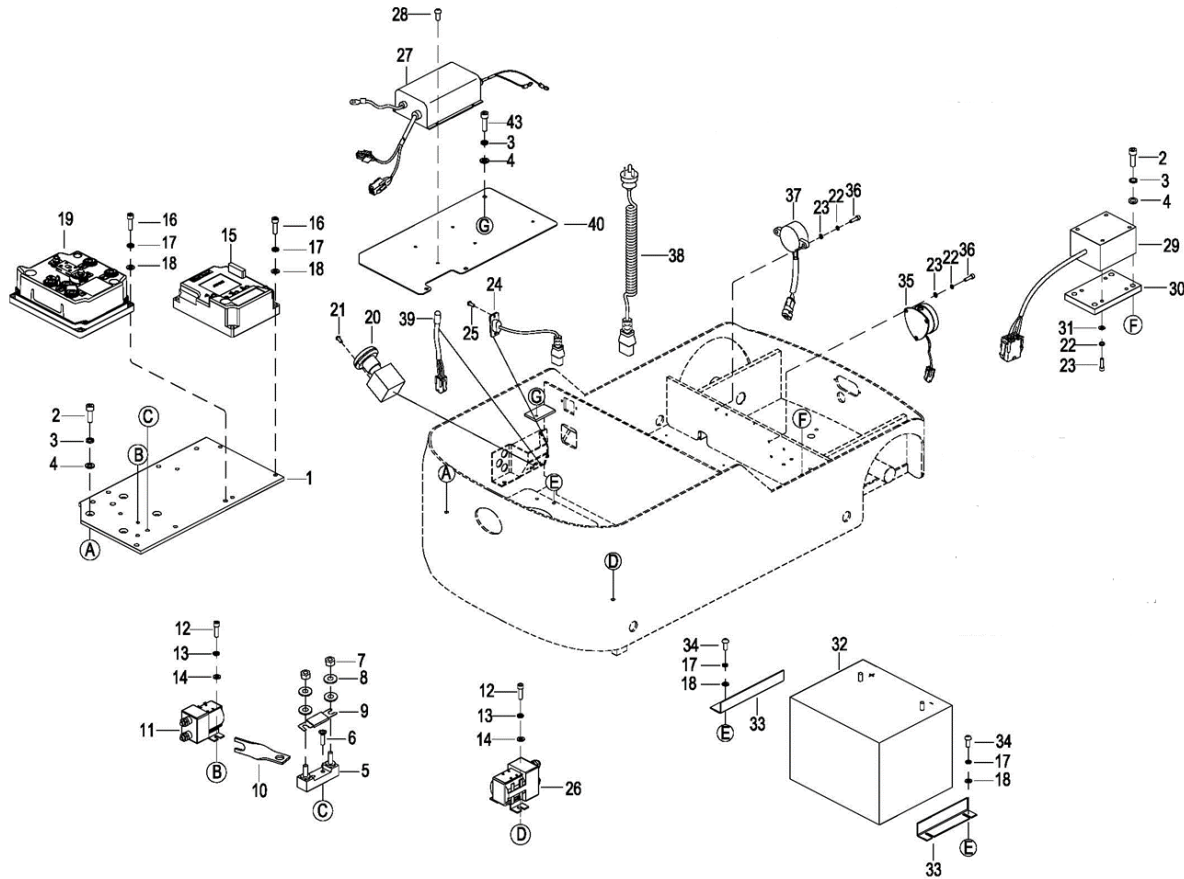

EC_0009

Figure 9-2 Battery Assembly

9-10.PLATFORM CABLE REPLACEMENT.

9-10.1.Three Stage Mast

NOTE: The Three Stage Mast version uses two protective chains on the harness's.

1. With the lift vehicle wheels securely blocked, raise the Platform approximately three feet and position blocks or strong supports under Platform and mast channels.
2. Lower Platform onto the support. Check that arrangement is secure before proceeding.
3. Engage the emergency power disconnect switch and turn off key switch.
4. Disconnect the electrical connectors at each end of the over the mast cable.
5. At each end of the plastic chain(s) remove the screws and disconnect mount from bracket(s).
6. Disconnect protective chain from the mount(s).
7. Remove the harness(es) from protective chain(s).
8. Lift harness with protective chain from sheave.
9. Remove harness from the protective chain.
10. Remove the ties securing the harness to bracket.
11. Remove two screws, two lock washers, two flat washers and clamp.
12. Remove two screws and disconnect mount from bracket.
13. Disconnect protective chain from mount.
14. Remove the two clamps from brackets by removing screws, lock washers, flat washers.
15. Remove two screws and disconnect mount from bracket.
16. Disconnect protective chain from mount.
17. Lift harness with protective chain from sheave.
18. Remove harness from the protective chain.
19. Install new harness by reversing the steps above.

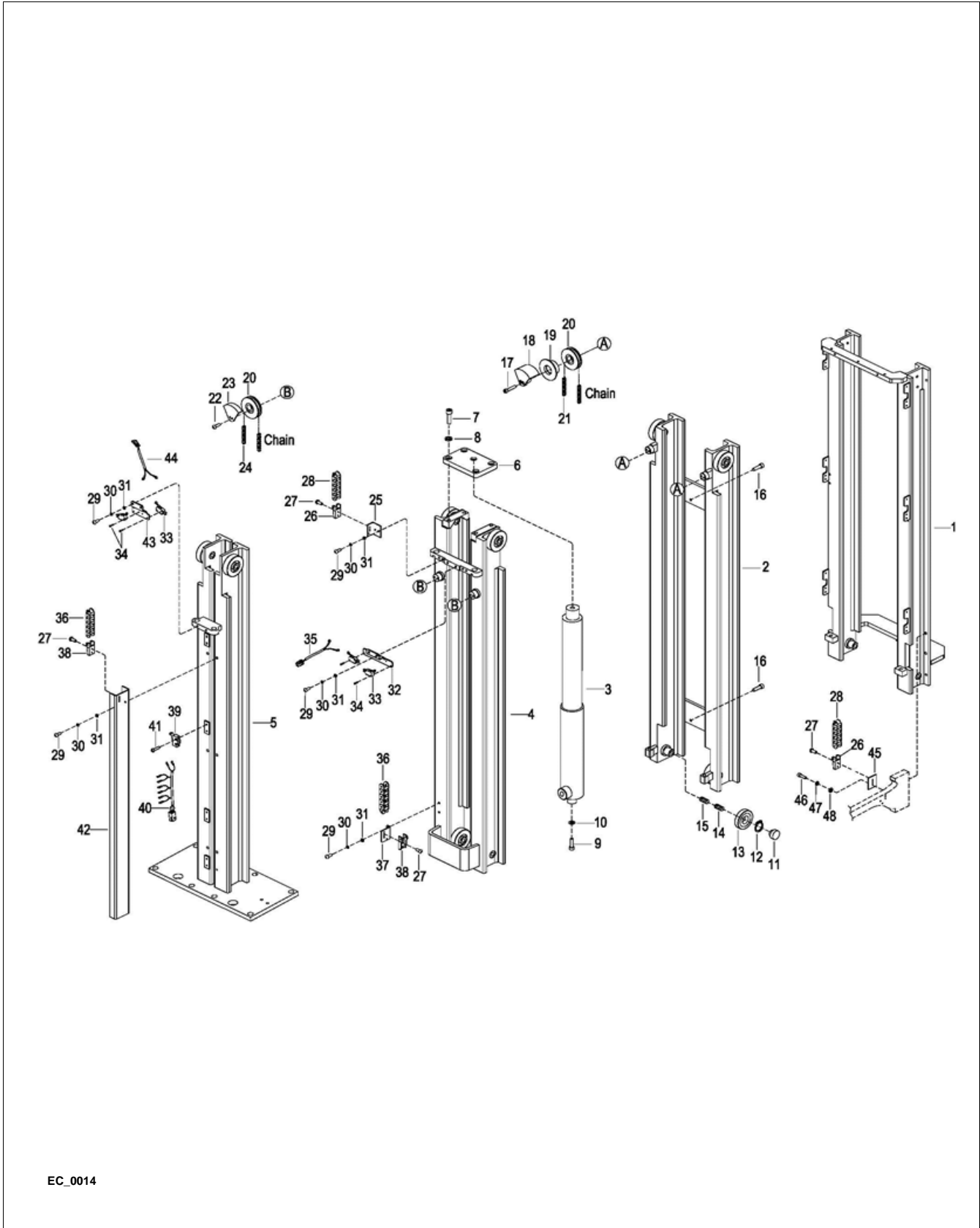

EC_0014

Figure 9-3 Elevation System - Breakdown

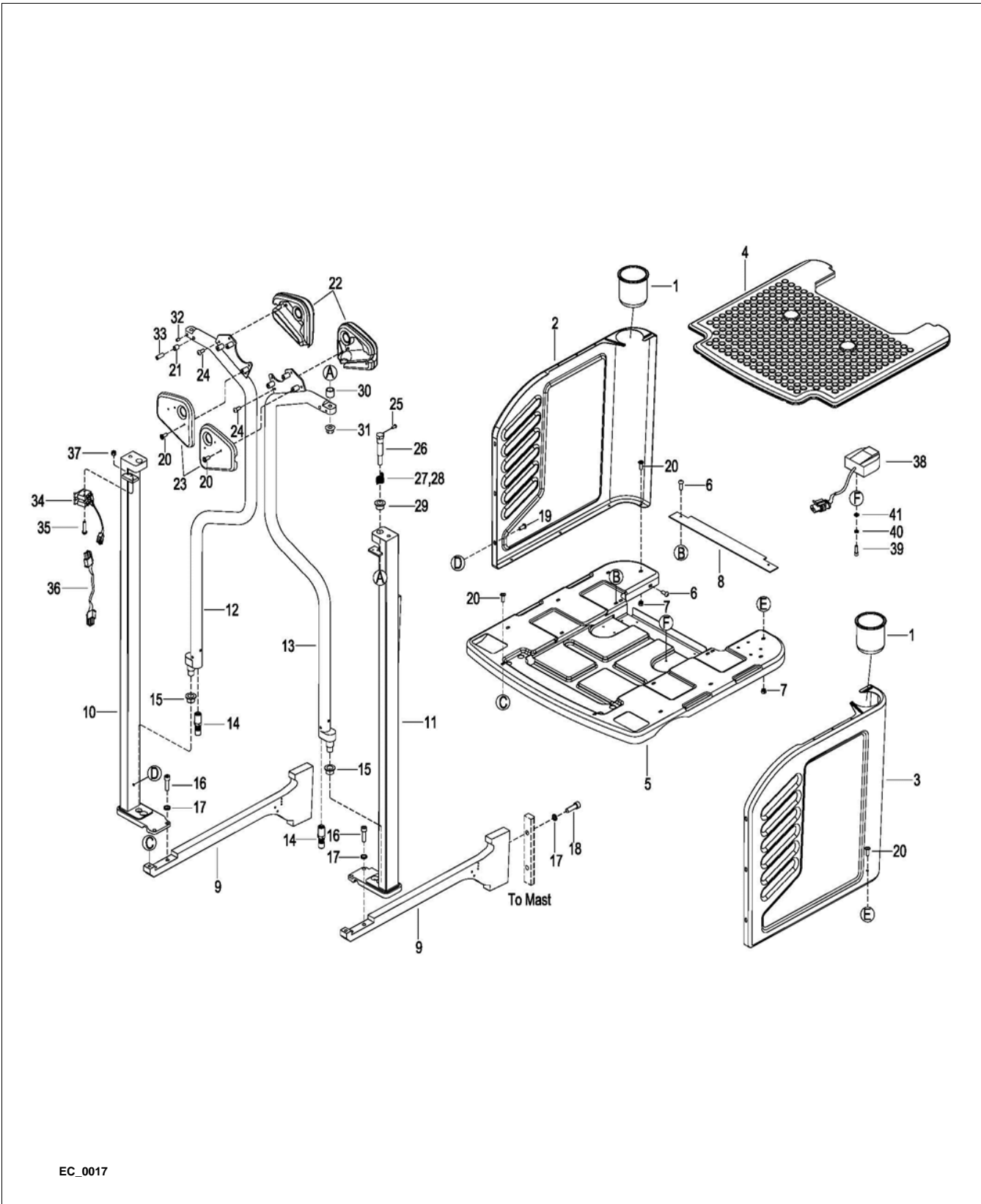

EC_0017

Figure 9-4 Platform

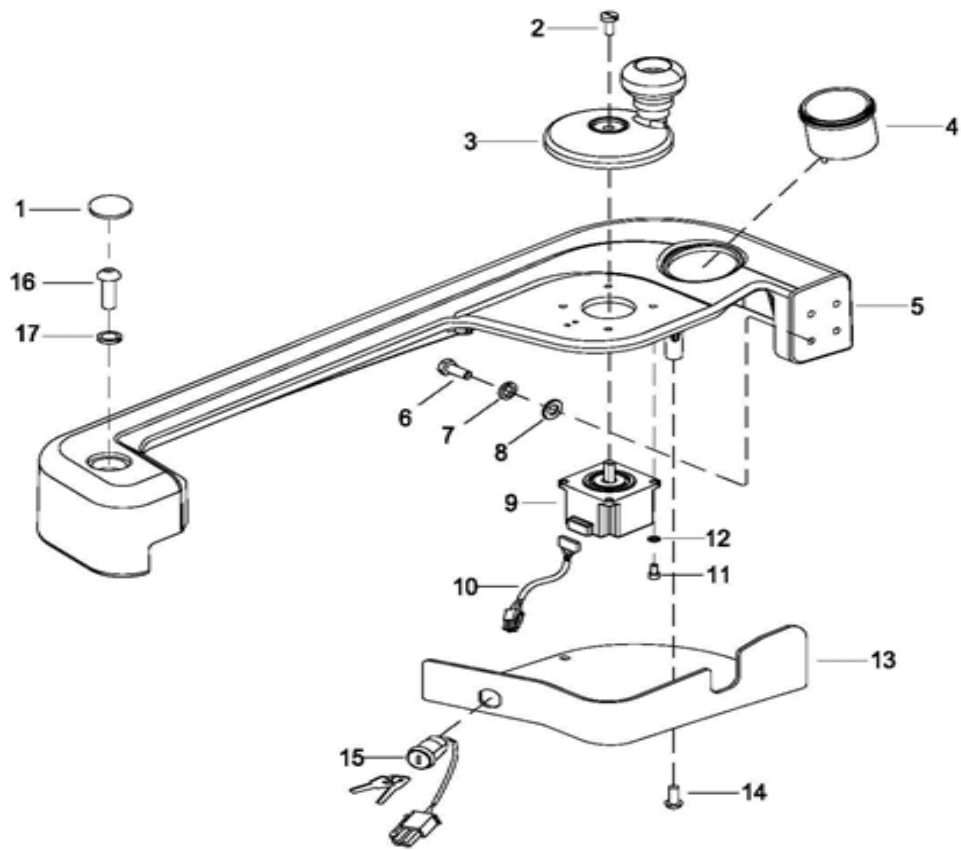

EC_0005

Figure 9-5 Operating Control Assembly - Left

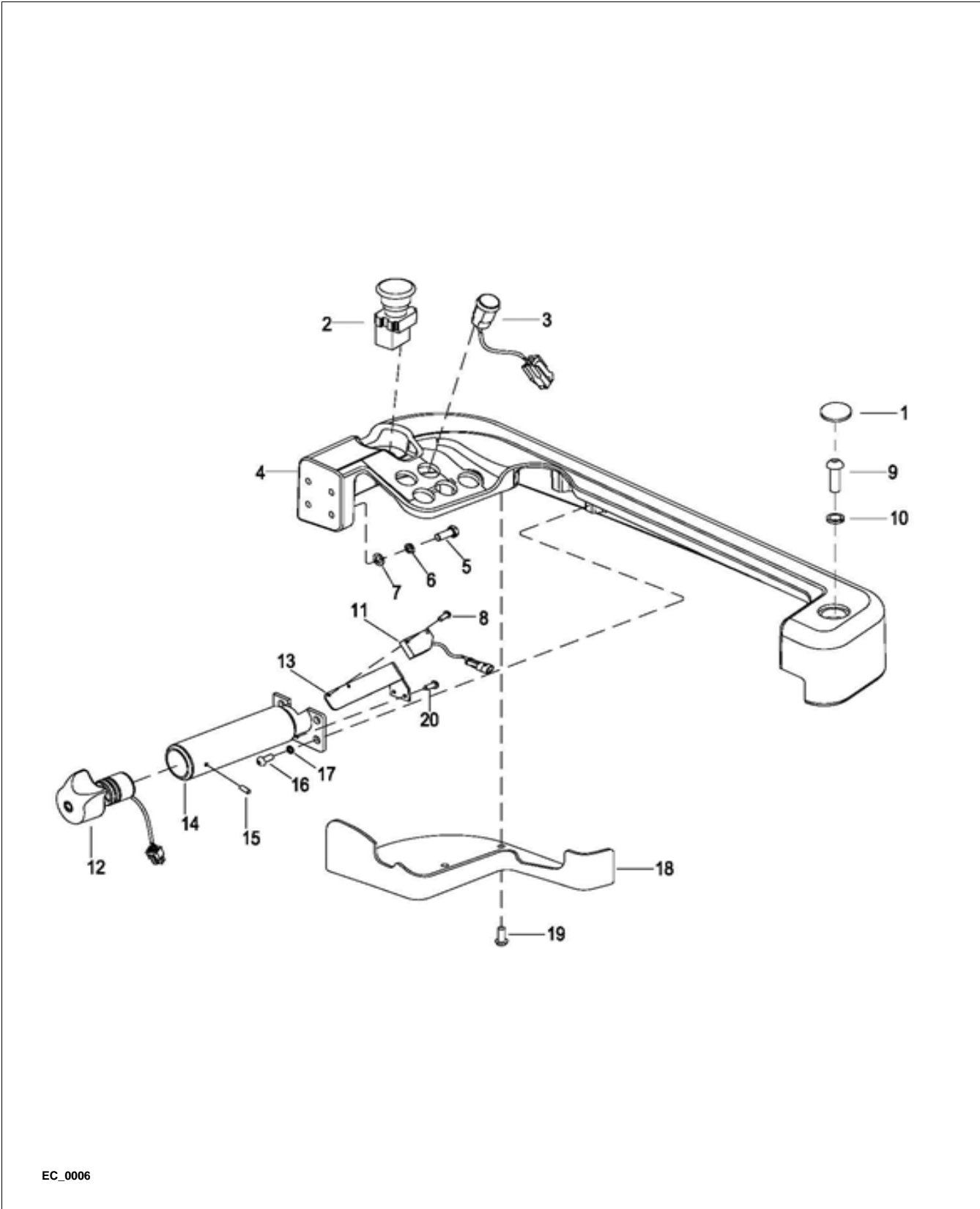

EC_0006

Figure 9-6 Operating Control Assembly - Right

NOTES

SECTION 10 OPTIONAL EQUIPMENT

10-1. INDUSTRIAL BATTERY

Contact you authorized Blue Giant dealer for information on optional batteries and battery chargers.

NOTES

SECTION 11 ILLUSTRATED PARTS BREAKDOWN

Following is an illustrated parts breakdown of assemblies and parts associated with the BG Zero Electric Access Vehicle.

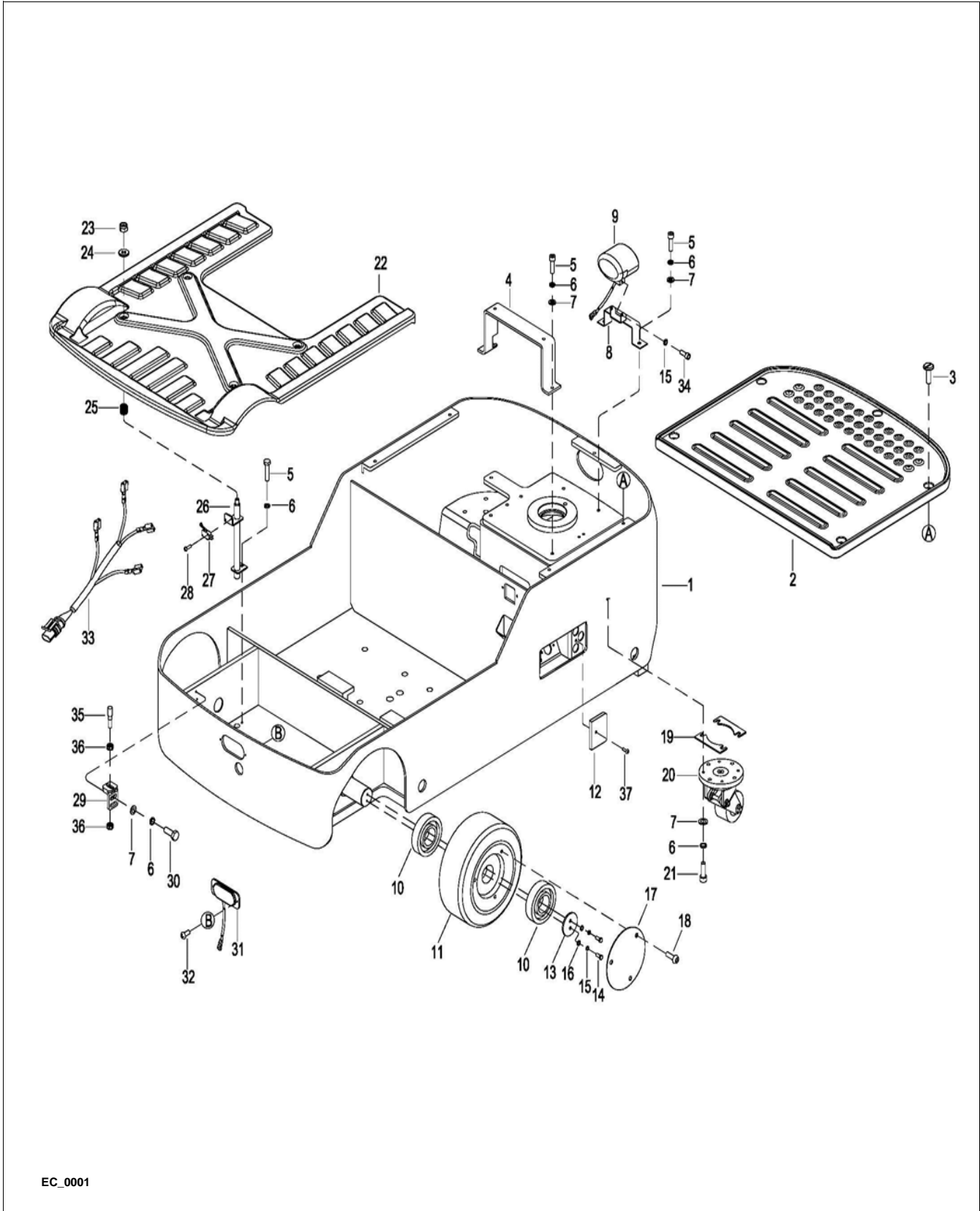

EC_0001

Figure 11-1 Frame

Frame

POS.	PART NUMBER	DESCRIPTION	QTY. REQD.	NOTES
1	1600-101000-A0	FRAME	1	
2	1600-103000-A0	TRAY	1	
3	3020-100000-05	SCREW M6×20	5	
4	1600-100002-00	BRACKET	1	
5	0000-000242-00	BOLT M8×16	8	
6	0000-000159-00	LOCK WASHER Ø8	20	
7	0000-000105-00	FLAT WASHER Ø8	16	
8	1600-104000-00	BRACKET	1	
9	1600-510006-00	BLUE LIGHT	1	
10	0000-000857-00	BEARING	4	
11	1600-10200X-00	LOAD WHEEL	2	
12	1600-100001-A0	COVER	1	
13	2320-600003-00	BAFFLE	2	
14	0000-000274-00	BOLT M6×25	4	
15	0000-000056-00	LOCK WASHER Ø6	6	
16	0000-000123-00	FLAT WASHER Ø6	4	
17	2320-600002-00	BAFFLE	2	
18	0000-000700-00	SCREW M8×16	6	
19	2140-140005-00	WASHER	4	
20	CK10-170000-00	CASTER ASSEMBLY	2	
21	0000-000322-00	SCREW M8×25	8	
22	1600-100007-A0	PLATE	1	
23	0000-000426-00	NUT M10	4	
24	0000-000175-00	FLAT WASHER Ø10	4	
25	1600-100008-A0	SPRING	4	
26	1600-100200-A0	MOUNTING POST	4	
27	1115-500017-00	MICRO SWITCH	4	
28	0000-000992-00	SCREW M3×12	8	
29	1600-100100-A0	BRACKET	2	
30	0000-000255-00	BOLT M8×20	4	
31	1600-510008-00	FLASH LIGHT	1	
32	0000-000646-00	SCREW M4×10	3	
33	1600-520007-10	SWITCH WIRE HARNESS	1	
34	0000-000077-00	SCREW M6×12	2	
35	1600-700011-00	PIN	2	
36	0000-000550-00	NUT M8	4	
37	0000-000701-00	SCREW M4×10	1	

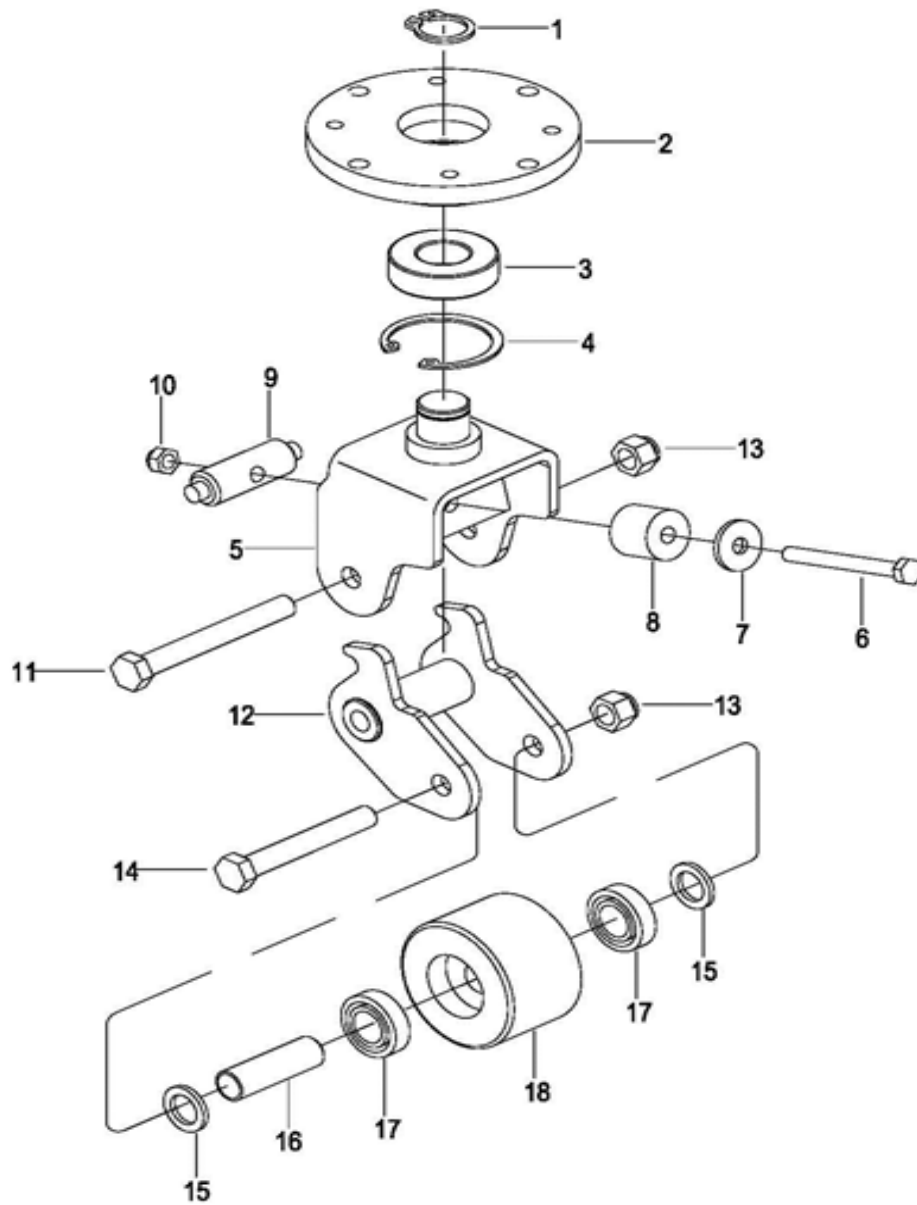

EC_0002

Figure 11-2 Caster Assembly

Caster Assembly

POS.	PART NUMBER	DESCRIPTION	QTY. REQD.	NOTES
--	CK10-170000-00	CASTER ASSEMBLY	2	2 Caster Assemblies user per vehicle. The qty. of parts listed below is per Caster Assembly.
1	0000-000294-00	RETAINER RING Ø25	1	
2	CK10-171001-00	CASTER SUPPORT	1	
3	0000-000100-00	BEARING	1	
4	0000-000758-00	ELASTIC COLLAR Ø52	1	
5	1115-032300-AA	CASTER SUPPORT	1	
6	0000-000281-00	BOLT M8×80	1	
7	0000-000373-00	FLAT WASHER Ø12	1	
8	CK10-171004-00	BUFFER BLOCK	1	
9	1115-032001-A0	ROD	1	
10	0000-000740-00	NUT M8	1	
11	3010-020000-45	BOLT M12×100	1	
12	1115-032200-A0	WHEEL BRACKET	1	
13	0000-001334-00	NUT M12	2	
14	3010-010000-31	BOLT M12×85	1	
15	0000-000435-00	FLAT WASHER Ø20	2	
16	1120-143001-00	SHAFT	1	
17	0000-000020-00	BEARING	2	
18	1115-172101-HA	PU WHEEL	1	

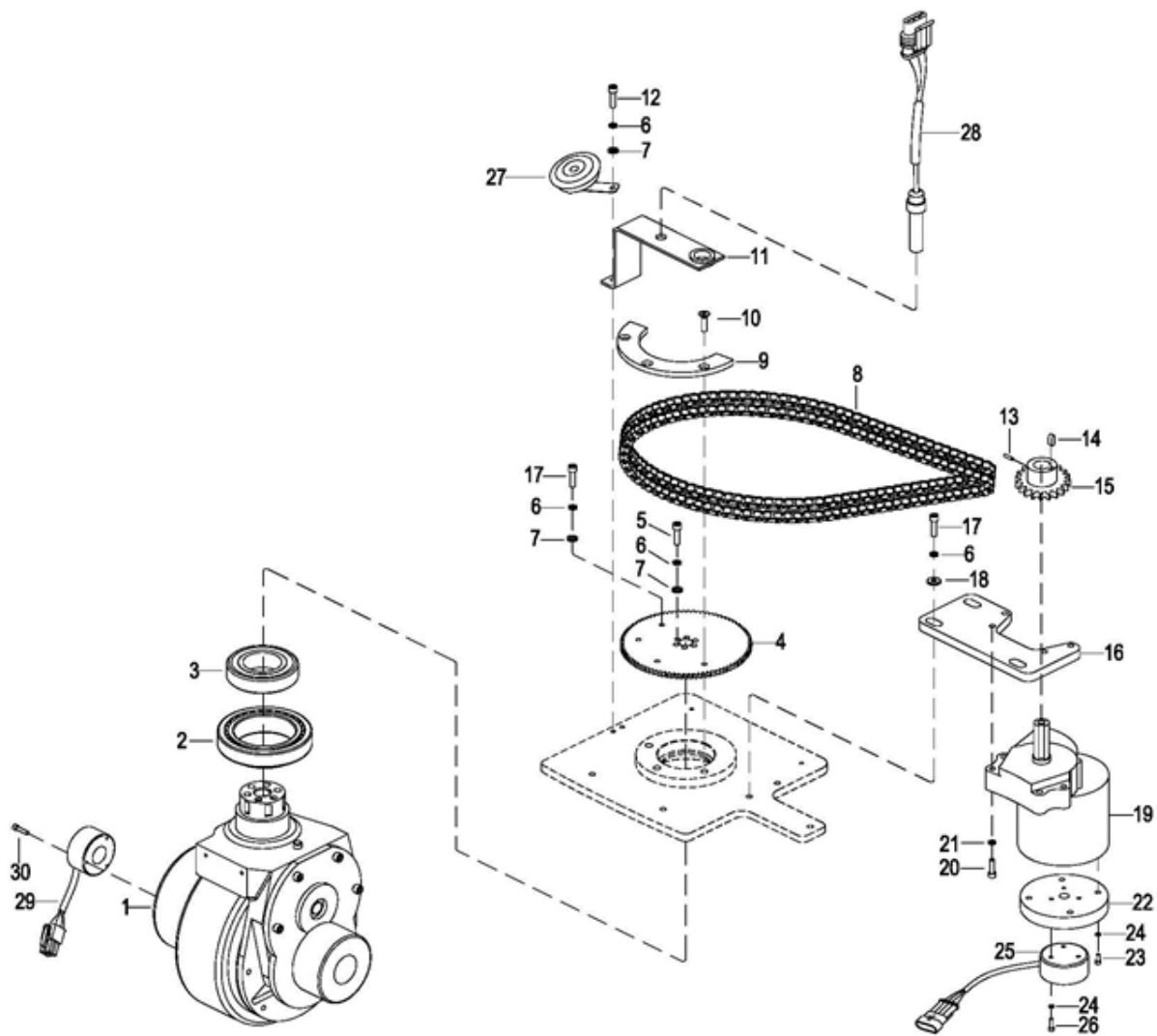

EC_0003

Figure 11-3 Drive System

Drive System

POS.	PART NUMBER	DESCRIPTION	QTY. REQD.	NOTES
1	1600-210000-A0	DRIVE MOTOR	1	
2	0000-000668-00	BEARING	1	
3	0000-000657-00	BEARING	1	
4	1600-200005-00	CHAIN GEAR	1	
5	0000-000154-00	SCREW M8×35	6	
6	0000-000159-00	LOCK WASHER Ø8	12	
7	0000-000105-00	FLAT WASHER Ø8	9	
8	1600-200100-00	CHAIN	1	
9	1600-200004-00	INDUCTION PLATE	1	
10	0000-000177-00	SCREW M8×12	3	
11	1600-200006-00	PLATE	1	
12	0000-000109-00	SCREW M8×16	2	
13	3020-050000-17	SCREW M5×8	1	
14	0000-001253-00	KEY 6X6X25	1	
15	1600-200002-00	CHAIN GEAR	1	
16	1600-200003-00	PLATE	1	
17	0000-000151-00	SCREW M8×25	4	
18	0000-000210-00	FLAT WASHER Ø8	3	
19	1600-220000-00	STEERING MOTOR	1	
20	0000-000384-00	SCREW M6×40	4	
21	0000-000056-00	LOCK WASHER Ø6	4	
22	1600-200001-00	PLATE	1	
23	3020-010000-49	SCREW M4×8	4	
24	0000-000122-00	LOCK WASHER Ø4	7	
25	3712-403000-00	ENCODER	1	
26	0000-001031-00	SCREW M4×30	3	
27	1120-500003-00	HORN	1	
28	1280-520009-10	SWITCH WIRE HARNESS II	1	
29	1600-200100-A0	ENCODER	1	
30	3020-010001-16	SCREW M4×20	3	

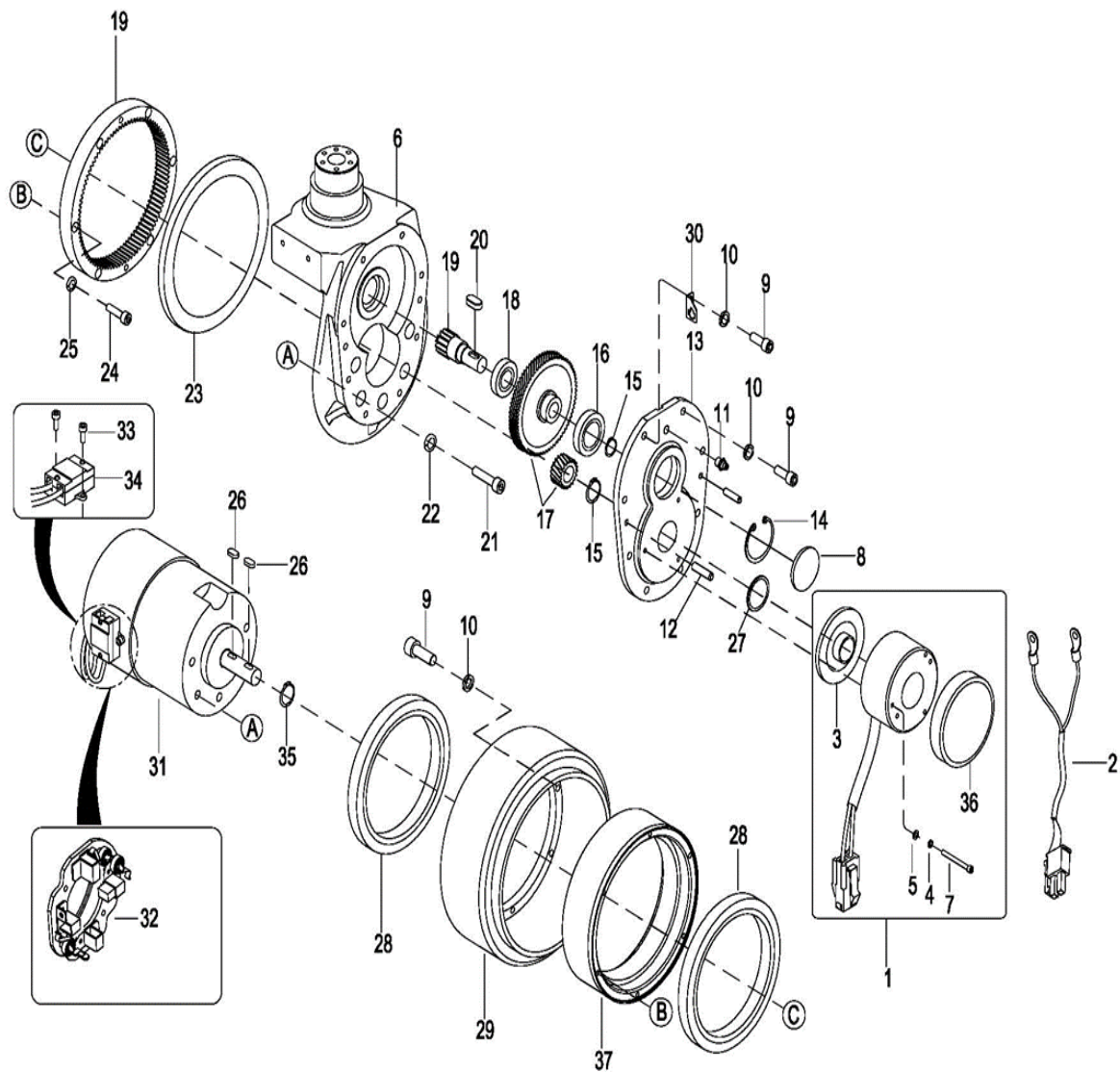

EC_0004

Figure 11-4 Transmission, Motor & Brake Assembly

Transmission, Motor & Brake Assembly

POS.	PART NUMBER	DESCRIPTION	QTY. REQD.	NOTES
1	1115-520012-10	BRAKE ASSEMBLY	1	
2	1600-520013-0A	BRAKE RELEASE HARNESS	1	
3	1115-240001-00	BRAKE	1	
4	0000-000122-00	LOCK WASHER Ø4	3	
5	0000-000089-00	FLAT WASHER Ø4	3	
6	2108-200002-0C	GEAR BOX CASING	1	
7	0000-000665-00	SCREW M4×45	3	
8	1115-200007-0A	CAP	1	
9	0000-000386-00	SCREW M6×20	14	
10	0000-000056-00	LOCK WASHER Ø6	14	
11	0000-000013-00	GREASE FITTING M8	1	
12	0000-001022-00	PIN Ø6×20	2	
13	1115-200001-0A	GEAR BOX CAP	1	
14	0000-000658-00	CLIP Ø42	1	
15	0000-000659-00	CLIP Ø15	2	
16	0000-000667-00	BEARING	1	
17	1600-GSX-10	GEAR KIT	1	
18	0000-000680-00	BEARING	1	
19	1115-GSX-20	GEAR KIT	1	
20	0000-001020-00	PARALLEL KEY 5×5×16	1	
21	0000-000026-00	SCREW M8×30	5	
22	0000-000159-00	LOCK WASHER Ø8	5	
23	0000-000670-00	OIL SEAL Ø155×172×10	1	
24	3020-010000-91	SCREW M5×25	6	
25	0000-000206-00	LOCK WASHER Ø5	6	
26	0000-001021-00	PARALLEL KEY 5×5×10	2	
27	0000-000671-00	OIL SEAL Ø16×28×7	1	
28	0000-000663-00	BEARING	2	
29	1115-220000-C0	DRIVE WHEEL	1	
30	1115-200020-00	PLATE	1	
31	1115-250000-10	MOTOR	1	
32	1115-25000X-00	BRUSH ASSEMBLY	1	
33	0000-000004-00	SCREW M5×12	2	
34	1115-231000-00	BRACKET	1	
35	0000-000589-00	CLIP Ø16	1	
36	1115-240002-0A	SCRAPER SEAL	1	
37	1115-200013-00	INNER RIM	1	

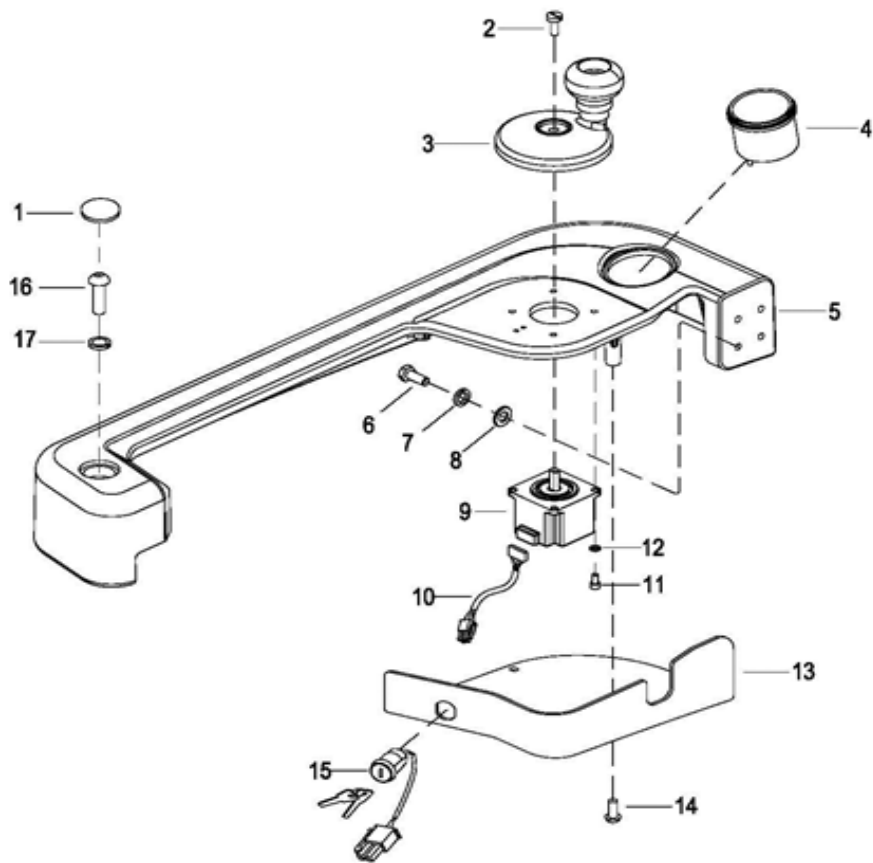

EC_0005

Figure 11-5 Operating Control Assembly (Left)

Operating Control Assembly (Left)

POS.	PART NUMBER	DESCRIPTION	QTY. REQD.	NOTES
1	1600-300004-00	RUBBER	1	
2	302010000010	SCREW M3×10	1	
3	1600-30000X-00	STEERING WHEEL	1	
4	1600-512000-00	METER	1	
5	1600-300200-00	LEFT ARMREST	1	
6	0000-000278-00	BOLT M8×30	3	
7	0000-000159-00	LOCK WASHER Ø8	3	
8	0000-000105-00	FLAT WASHER Ø8	3	
9	1600-513000-00	STEPPING MOTOR	1	
10	3712-420004-00	MOTOR WIRE HARNESS	1	
11	0000-000004-00	SCREW M5×12	4	
12	0000-000206-00	LOCK WASHER Ø5	4	
13	1600-300002-A0	BOTTOM COVER	1	
14	0000-000381-00	SCREW M5×10	4	
15	1115-520003-0A	KEY SWITCH	1	
16	0000-001410-00	SCREW M12×30	1	
17	0000-000060-00	LOCK WASHER Ø12	1	

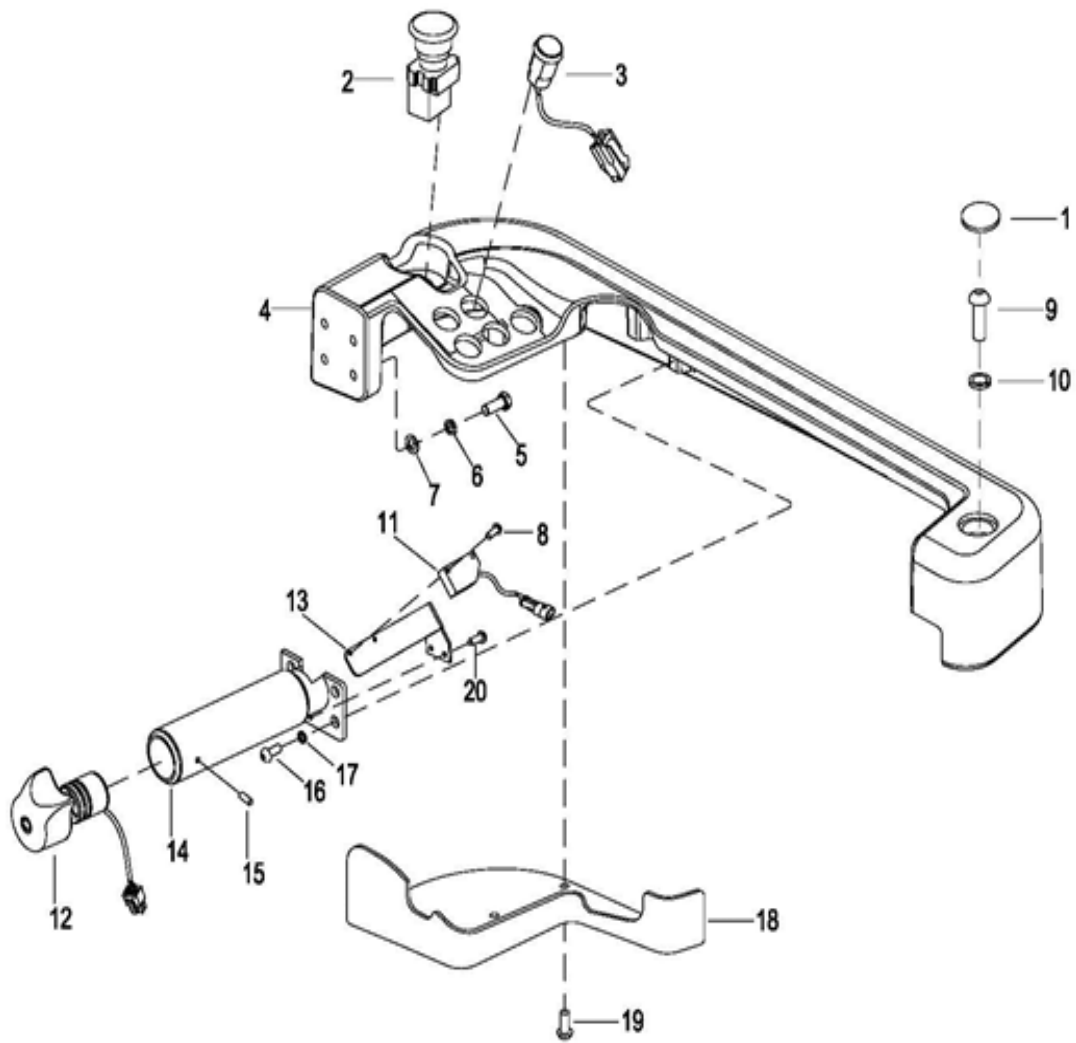

EC_0006

Figure 11-6 Operating Control Assembly (Right)

Operating Control Assembly (Right)

POS.	PART NUMBER	DESCRIPTION	QTY. REQD.	NOTES
1	1600-300004-00	RUBBER	1	
2	3218-604000-00	EMERGENCY STOP SWITCH	1	
3	CK11-520012-00	BUTTON SWITCH	5	Used up to Serial Number 2291200219
3a	CK11-520012-0A	BUTTON SWITCH	5	Used from Serial Number 2291200220
4	1600-300100-00	RIGHT ARMREST	1	
5	0000-000278-00	BOLT M8×30	3	
6	0000-000159-00	LOCK WASHER Ø8	3	
7	0000-000105-00	FLAT WASHER Ø8	3	
8	0000-000992-00	SCREW M3×12	2	
9	0000-001410-00	SCREW M12×30	1	
10	0000-000060-00	LOCK WASHER Ø12	1	
11	1600-520008-00	SWITCH	1	
12	1600-511000-00	ACCELERATOR ASSEMBLY	1	
13	1600-300303-0A	BRACKET	1	
14	1600-300300-0A	HANDLE	1	
15	3020-050000-19	SCREW M4×4	2	
16	0000-000371-00	SCREW M6×16	4	
17	0000-000056-00	LOCK WASHER Ø6	4	
18	1600-300001-00	BOTTOM COVER	1	
19	0000-000381-00	SCREW M5×10	4	
20	0000-000701-00	SCREW M4×10	2	

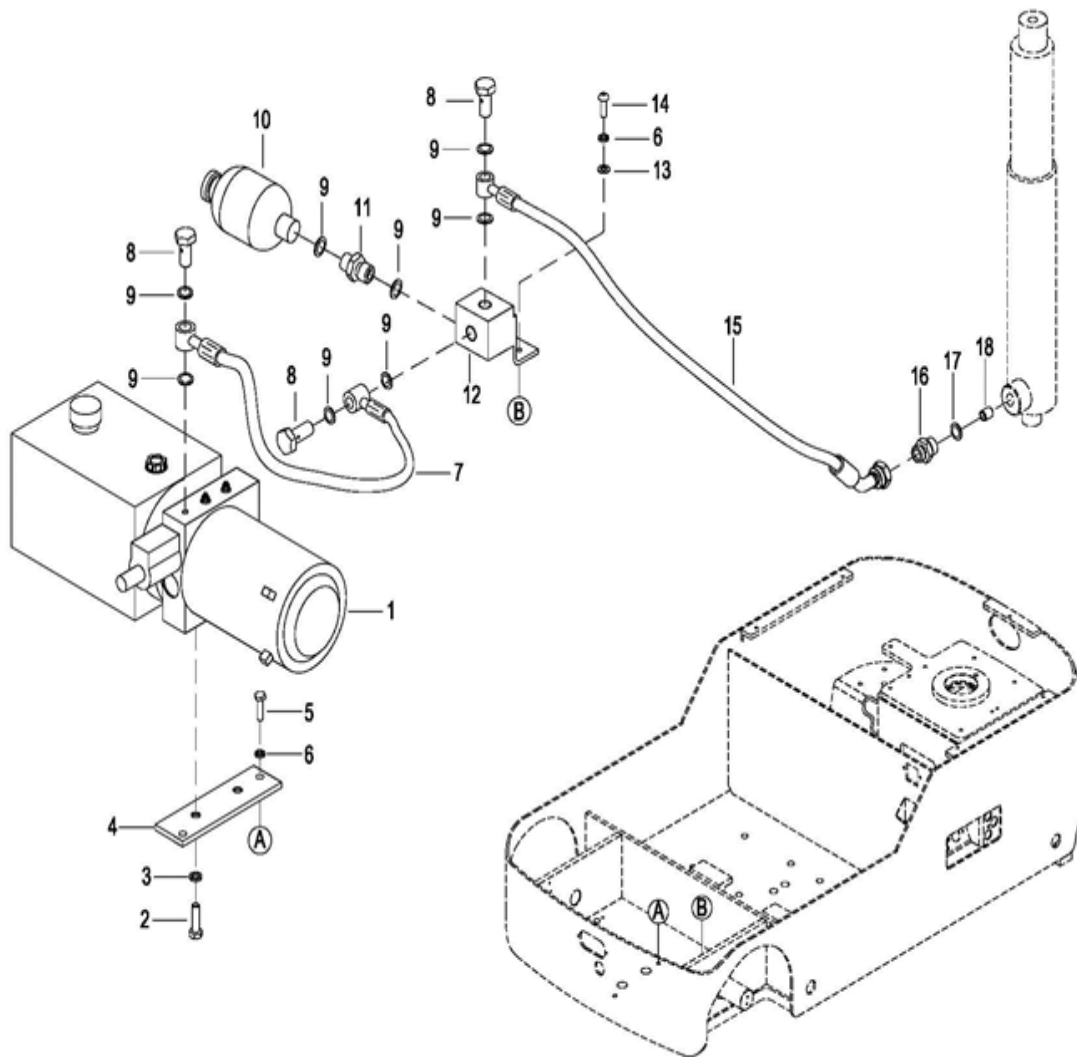

EC_0007

Figure 11-7 Hydraulic System

Hydraulic System

POS.	PART NUMBER	DESCRIPTION	QTY. REQD.	NOTES
1	1600-421000-00	HYDRAULIC PUMP	1	
2	0000-000270-00	SCREW M10×20	2	
3	0000-000063-00	LOCK WASHER Ø10	2	
4	1600-100001-00	PLATE	1	
5	0000-000259-00	BOLT M6×16	2	
6	0000-000056-00	LOCK WASHER Ø6	2	
7	1600-431000-00	OIL PIPE I	1	
8	2402-143500-00	BOLT G1/4×35	3	
9	0000-000044-00	WASHER Ø14	8	
10	CK11-450000-00	ACCUMULATOR	1	
11	2701-141400-00	JOINT M14×1.5-M14×1.5	1	
12	2112-440000-10	BLOCK TEE	1	
13	0000-000437-00	FLAT WASHER Ø6	2	
14	0000-000371-00	SCREW M6×16	2	
15	1600-432000-0A	OIL PIPE II	1	
16	2702-381600-10	JOINT G3/8-M16×1.5	1	
17	0000-000515-00	WASHER Ø16	1	
18	2214-411000-R0	EXPLOSION RELIEF VALVE	1	

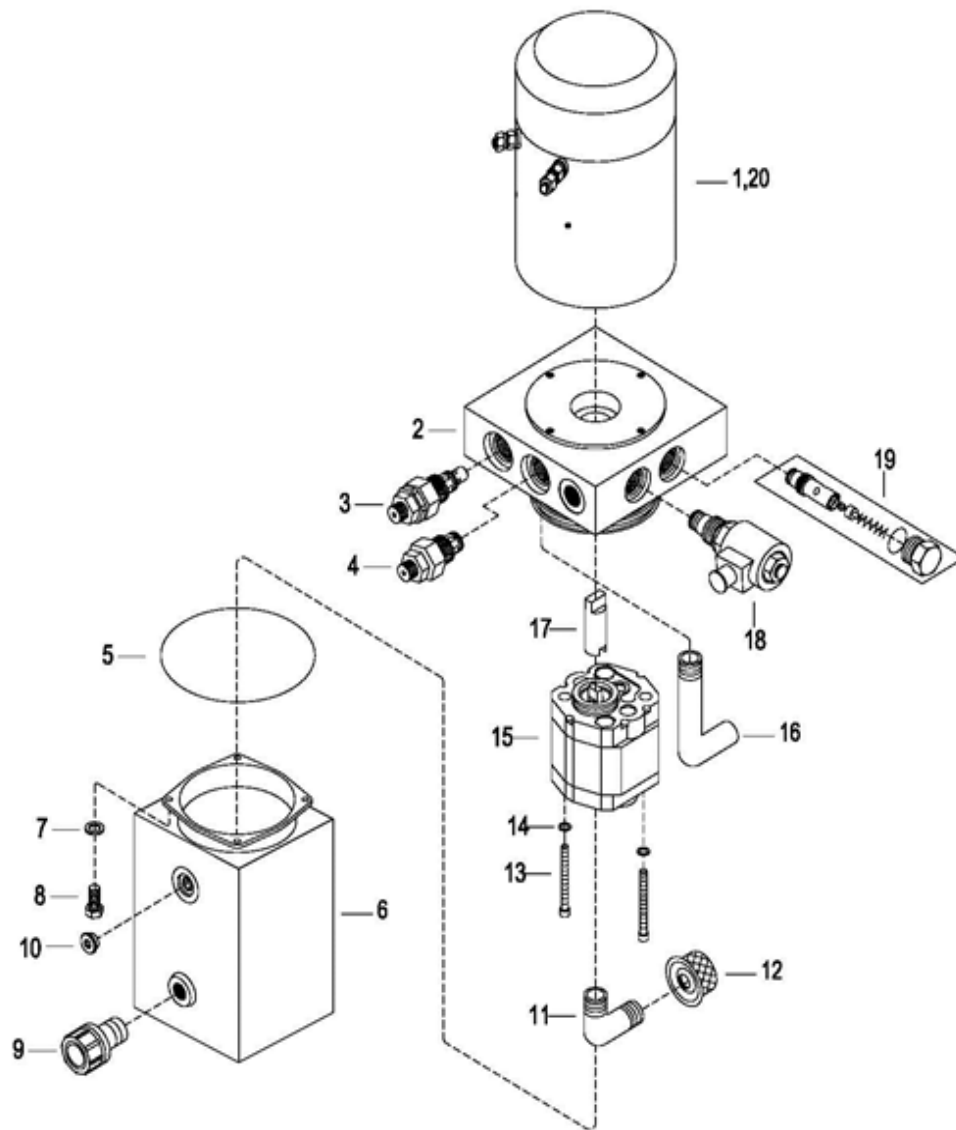

EC_0008

Figure 11-8 Hydraulic Pump Assembly

Hydraulic Pump Assembly

POS.	PART NUMBER	DESCRIPTION	QTY. REQD.	NOTES
1	ECK-421001-00	DC MOTOR 2.2KW/24V	1	
2	ECK-421002-00	VALVE PLATE	1	
3	ECK-421003-00	SAFETY VALVE	1	
4	ECK-421004-00	THROTTLE	1	
5	ECK-421005-00	O-RING 100X3.55	1	
6	ECK-421006-00	TANK 3L	1	
7	ECK-421007-00	FLAT WASHER Ø5	4	
8	ECK-421008-00	BOLT M5X10	4	
9	ECK-421022-00	AIR FILTER	1	
10	ECK-421021-00	OIL PLUG	1	
11	ECK-421011-00	SUCTION PIPE	1	
12	ECK-421012-00	OIL FILTER	1	
13	ECK-421013-00	SCREW M8X80	2	
14	ECK-421014-00	FLAT WASHER Ø8	2	
15	ECK-421015-00	GEAR PUMPS 2.0CC/R	1	
16	ECK-421016-00	NYLON TUBE	1	
17	ECK-421017-00	CONNECTING SHAFT	1	
18	ECK-421018-00	SOLENOID VALVE 24V	1	
19	ECK-421019-00	CHECK VALVE	1	
20	ECK-421020-00	BRUSH	1	

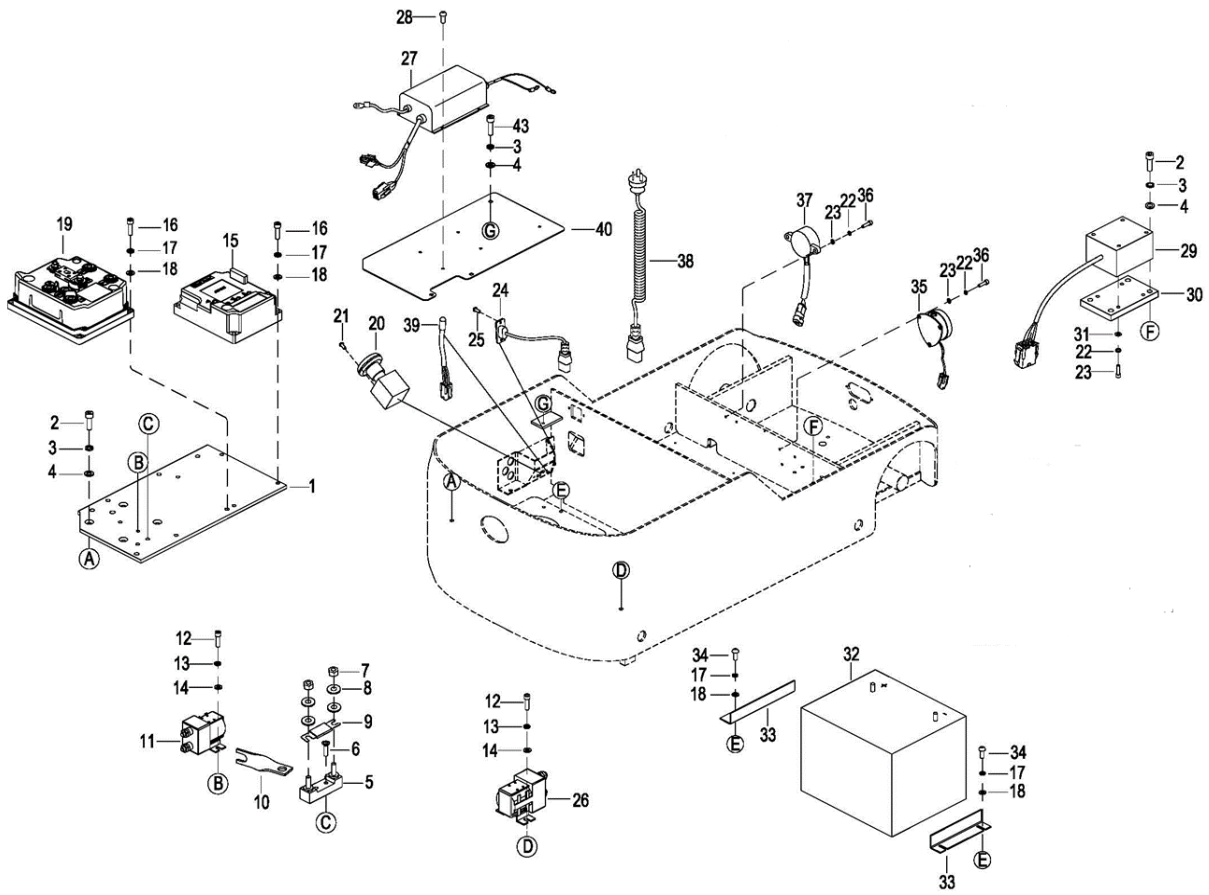

EC_0009

Figure 11-9 Electrical System

Electrical System

POS.	PART NUMBER	DESCRIPTION	QTY. REQD.	NOTES
1	1600-501001-00	BOARD	1	
2	0000-000321-00	SCREW M8X20	7	
3	0000-000159-00	LOCK WASHER Ø8	11	
4	0000-000105-00	FLAT WASHER Ø8	11	
5	1120-540001-00	STAND	1	
6	0000-000126-00	SCREW M6×16	2	
7	0000-000550-00	NUT M8	2	
8	0000-000210-00	FLAT WASHER Ø8	4	
9	1120-540002-00	FUSE 200A	1	
10	1120-530006-00	COPPER CONDUCTOR	1	
11	1120-500005-10	CONTACTOR	1	
12	0000-000004-00	SCREW M5×12	2	
13	0000-000206-00	LOCK WASHER Ø5	2	
14	0000-000128-00	FLAT WASHER Ø5	2	
15	1280-560002-10-F0	EPS CONTROLLER	1	
16	0000-000032-00	SCREW M6×25	8	
17	0000-000056-00	LOCK WASHER Ø6	12	
18	0000-000380-00	FLAT WASHER Ø6	12	
19	1600-510001-10-00	CONTROLLER DUALPMX	1	
20	1220-500001-00	EMERGENCY STOP SWITCH	1	
21	0000-000009-00	SCREW M4×12	2	
22	0000-000122-00	LOCK WASHER Ø4	9	
23	0000-000702-00	FLAT WASHER Ø4	9	
24	1600-520014-00	CHARGER SWITCHING LINE	1	
25	0000-000992-00	SCREW M3×12	2	
26	1600-530012-00	CONTACTOR 50A	1	
27	1600-510003-0A	CHARGER 15A	1	
28	0000-000479-00	SCREW M5×16	4	
29	1600-520016-00	LEVEL SENSOR	1	
30	CK10-510016-00	LEVEL SENSOR PLATE	1	
31	3020-010001-16	SCREW M4×20	4	
32	1118-500008-00	STORAGE BATTERY	2	
33	1600-100003-00	BAFFLE	A.R.	As Required
34	0000-000371-00	SCREW M6×16	4	
35	CK10-520011-00	BUZZER (LEVEL SENSOR)	1	
36	0000-001029-00	SCREW M4×12	5	
37	CK11-520011-00	BUZZER (LOWERING)	1	
38	1115-500006-10	CHARGER CABLE	1	
39	1115-520013-00	LED WIRE HARNESS	1	
40	1600-100009-A0	COVER	1	
43	0000-000242-00	BOLT M8×16	1	

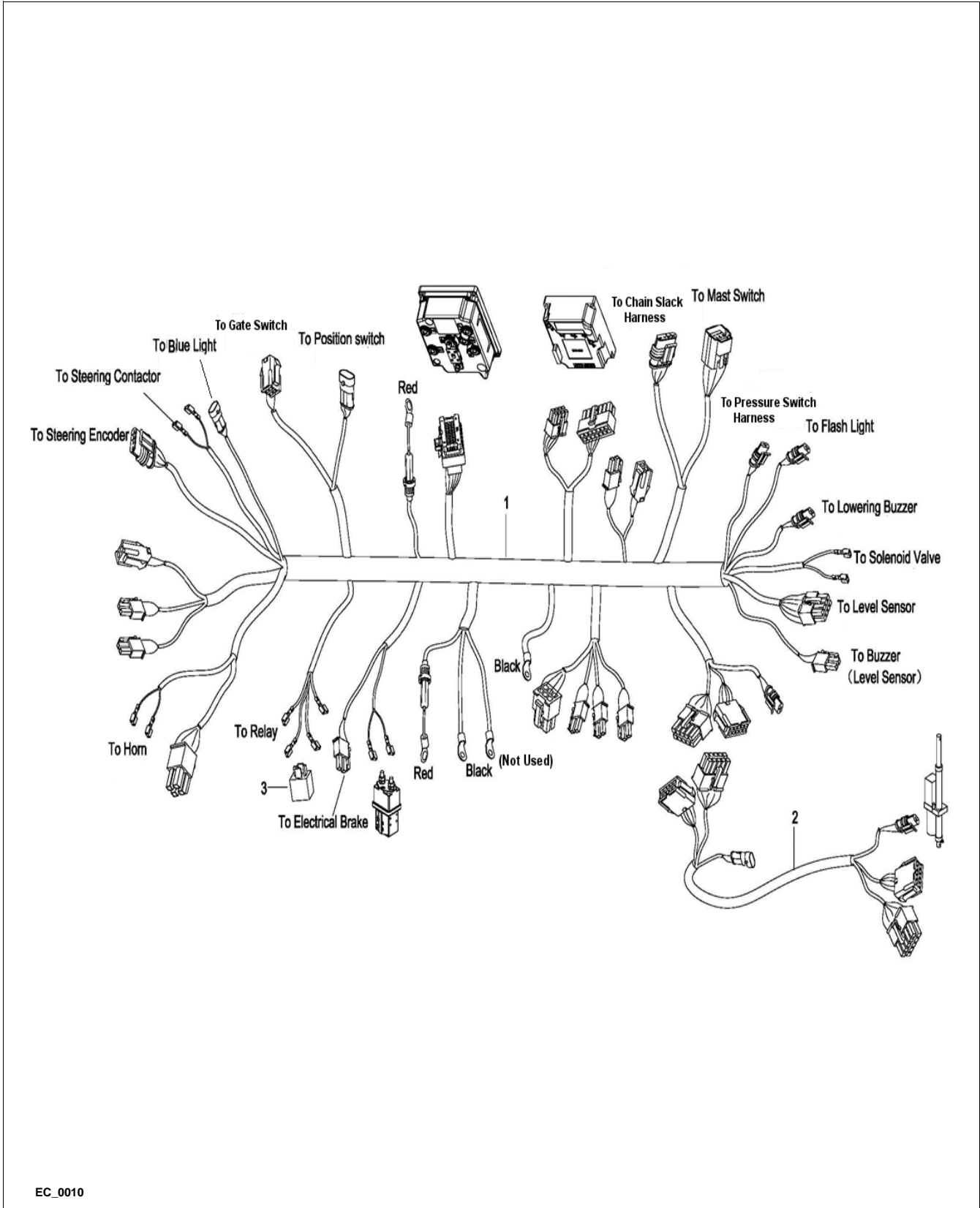

EC_0010

Figure 11-10 Wiring Harness 1

Wire Harness 1

POS.	PART NUMBER	DESCRIPTION	QTY. REQD.	NOTES
1	1600-520001-1A	MAIN WIRING HARNESS	1	
2	1600-520002-10	MULTI-CORE CABLE HARNESS	1	
3	LB00-200094-00	RELAY 24V	1	

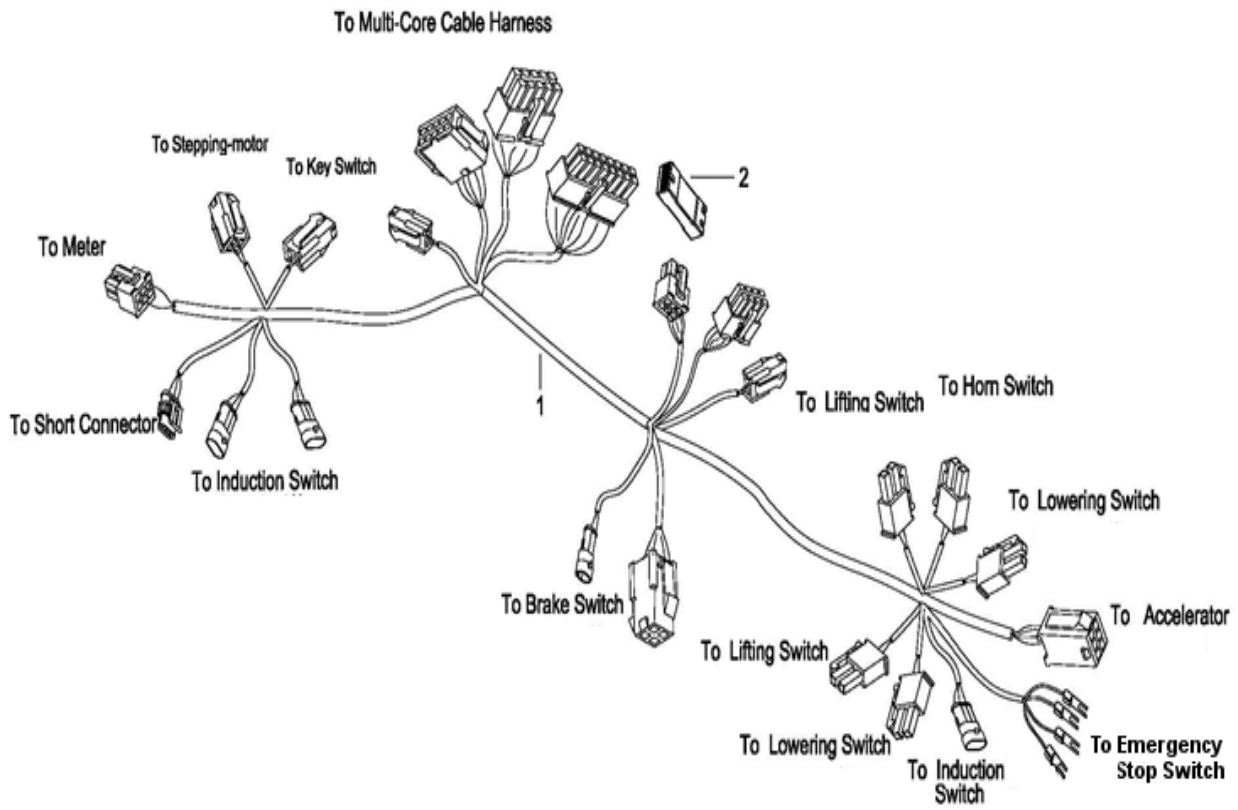

EC_0011

Figure 11-11 Wiring Harness 2

Wire Harness 2

POS.	PART NUMBER	DESCRIPTION	QTY. REQD.	NOTES
1	1600-520003-1A	PLATFORM HARNESS	1	
2	1600-510004-00	CONTROLLER CAN-TILLER	1	

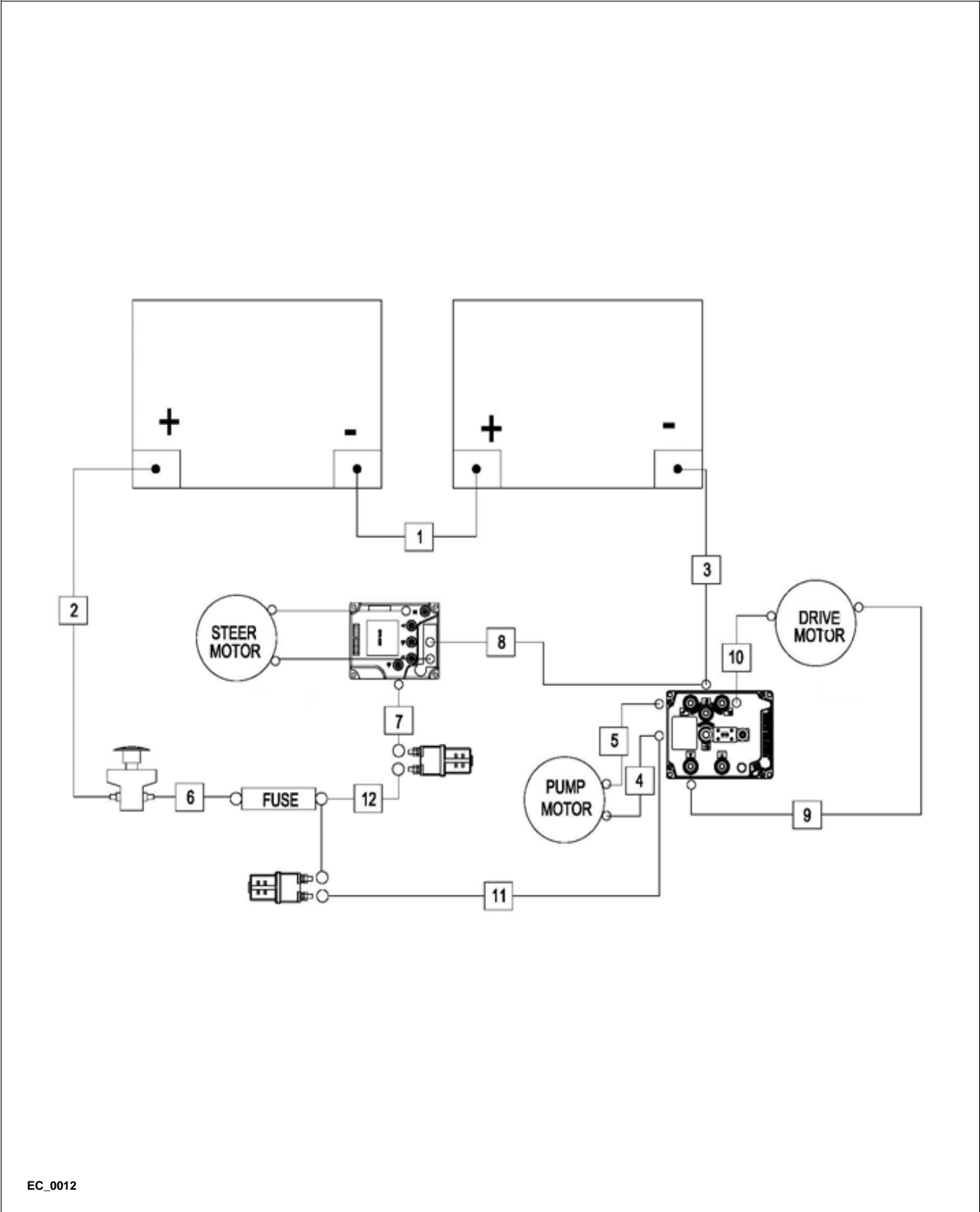
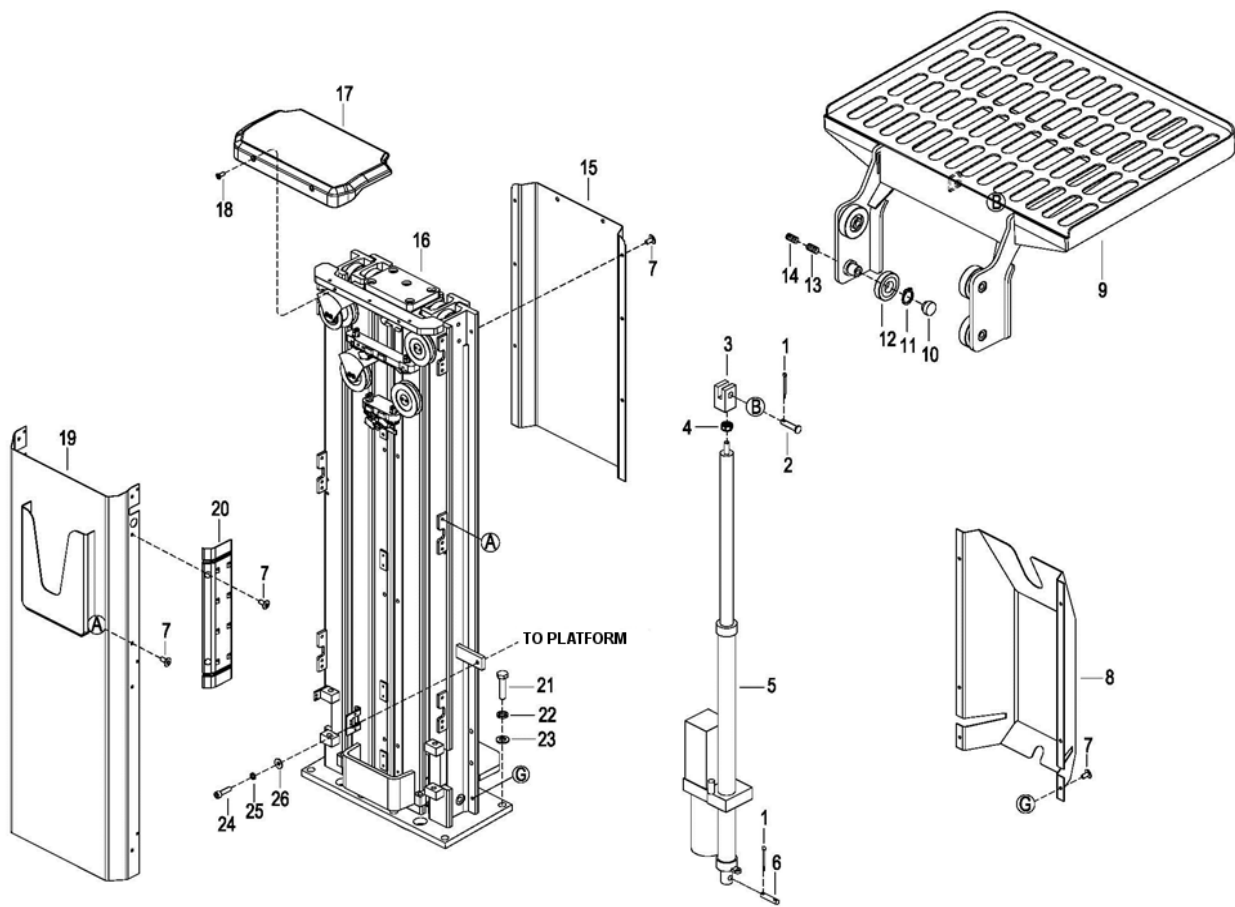

Figure 11-12 Wiring Cables

Wiring Cables

POS.	PART NUMBER	DESCRIPTION	QTY. REQD.	NOTES
1	1600-532003-00	BATTERY CONNECTING CABLE	1	
2	1600-532001-00	B CABLE+	1	
3	1600-532002-00	B CABLE-	1	
4	1600-530008-00	PUMP POWER CABLE +	1	
5	1600-530009-00	PUMP POWER CABLE -	1	
6	1600-530001-00	E-F CABLE	1	
7	1600-530004-00	EPS CABLE+	1	
8	1600-530005-00	EPS CABLE-	1	
9	1600-530002-10	STEERING MOTOR CABLE V	1	
10	1600-530003-10	STEERING MOTOR CABLE W	1	
11	1600-530010-00	CONTROLLER +	1	
12	1600-530011-00	EPS CONTROLLER CABLE	1	



EC_0013

Figure 11-13 Elevation System - Overview

Elevation System - Overview

POS.	PART NUMBER	DESCRIPTION	QTY. REQD.	NOTES
1	0000-000188-00	COTTER PIN Ø3.2X20	3	
2	3070-060000-22	SHAFT Ø10X32	1	
3	1600-660001-0A	PUSH ROD HEAD	1	
4	0000-000630-00	NUT M12	1	
5	1600-660000-0A	PUSH ROD	1	
6	3070-080000-01	SHAFT Ø10X55	1	
7	2028-000000-17	SCREW M6X12	20	
8	1600-600014-A0	BAFFLE	1	
9	1600-650000-00	CARRIAGE	1	
10	2108-600010-60	PLUGGING	4	
11	0000-000434-00	RETAINER RING Ø30	4	
12	1600-600010-00	ROLLER	4	
13	0000-001525-00	SCREW M12X10	4	
14	0000-000761-00	SCREW M12X20	4	
15	1600-600007-A0	FRONT COVER	1	
16	1600-60000X-00	MAST ASSEMBLY	1	
17	1600-600011-0B	MAST COVER	1	
18	2028-000000-18	SCREW M6X20	4	
19	1600-600008-A0	BACK COVER	1	
20	1600-700001-A0	SIDE COVER	2	
21	0000-000996-00	SCREW M16X45	8	
22	0000-000191-00	LOCK WASHER Ø16	8	
23	0000-000220-00	FLAT WASHER Ø16	8	
24	0000-000322-00	SCREW M8X25	2	
25	0000-000159-00	LOCK WASHER Ø8	2	
26	0000-000210-00	FLAT WASHER Ø8	2	

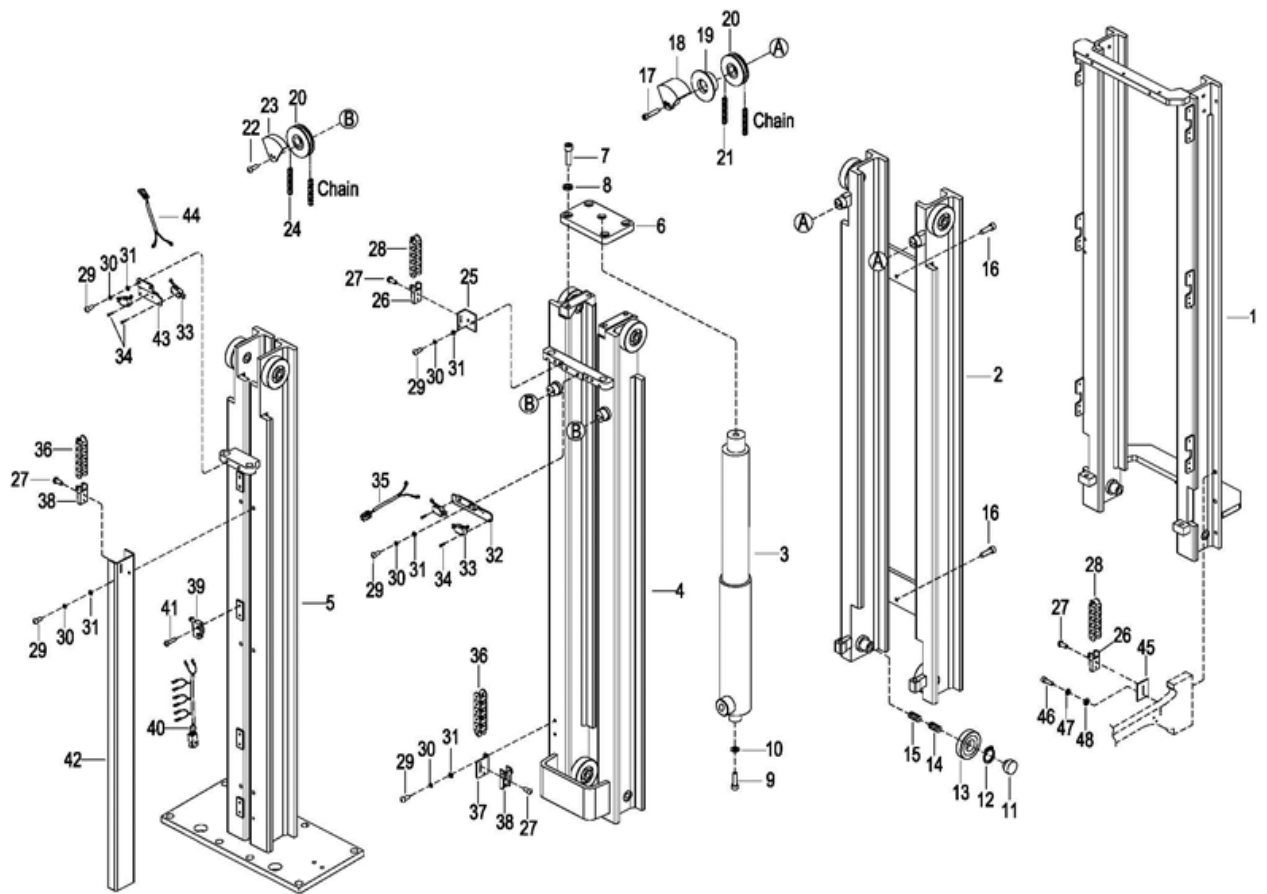

EC_0014

Figure 11-14 Elevation System - Breakdown

Elevation System - Breakdown

POS.	PART NUMBER	DESCRIPTION	QTY. REQD.	NOTES
1	1600-640000-A0	OUTER MAST	1	
2	1600-630000-00	MIDDLE MAST	1	
3	1600-411000-00	LIFT CYLINDER	1	
4	1600-620000-A0	INNER MAST	1	
5	1600-610000-A0	FRAME	1	
6	1600-600002-00	PLATE	1	
7	0000-000324-00	SCREW M10X30	5	
8	0000-000063-00	LOCK WASHER Ø10	5	
9	0000-000321-00	SCREW M8X20	1	
10	0000-000176-00	FLAT WASHER Ø8	1	
11	2108-600010-60	COLUMN	12	
12	0000-000434-00	RETAINER RING Ø30	12	
13	1600-600010-00	ROLLER	12	
14	0000-001525-00	SCREW M12X10	12	
15	0000-000761-00	SCREW M12X20	12	
16	0000-000151-00	SCREW M8X25	4	
17	0000-000384-00	SCREW M6X40	4	
18	1600-600200-00	PLATE II	2	
19	1600-600003-00	CHAIN WHEEL	2	
20	1600-600009-00	CHAIN ROLLER	4	
21	1600-600400-A0	CHAIN II	2	
22	0000-000371-00	SCREW M6X16	4	
23	1600-600100-00	PLATE I	2	
24	1600-600300-A0	CHAIN I	2	
25	1600-600004-00	MOUNTING PLATE I	2	
26	CK10-510005-00	DRAG HEAD II	4	
27	0000-000651-00	SCREW M4×8	16	
28	CK10-510003-00-14	DRAG CHAIN II	2	
29	0000-000021-00	SCREW M6X12	12	
30	0000-000056-00	LOCK WASHER Ø6	12	
31	0000-000380-00	FLAT WASHER Ø6	12	
32	1600-600016-A0	BRACKET II	1	
33	1115-500017-00	MICRO-SWITCH	4	
34	0000-000992-00	SCREW M3X12	8	
35	1600-520011-10	SWITCH WIRE HARNESS UP	1	
36	CK10-510003-00-13	DRAG CHAIN I	1	

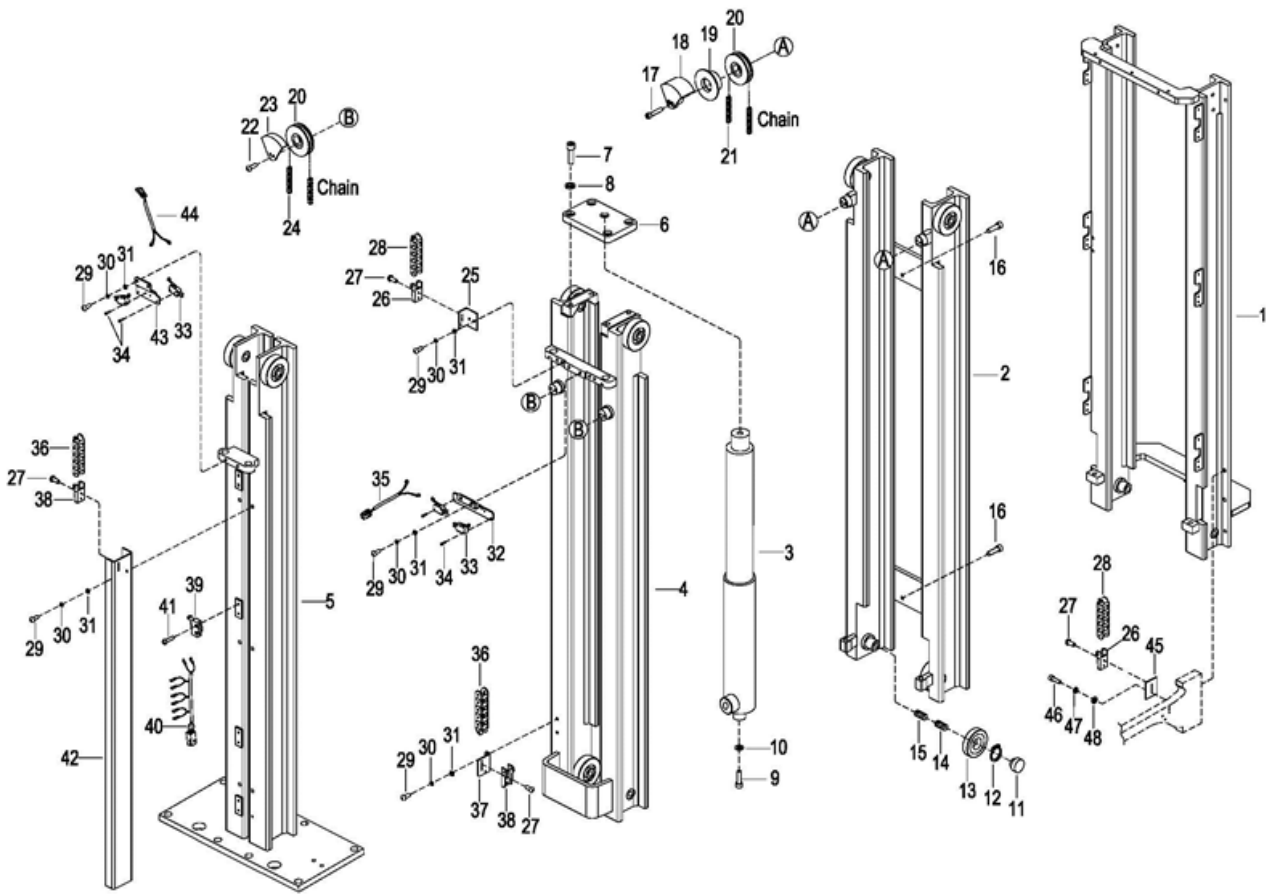

EC_0014

Figure 11-14 Elevation System - Breakdown - Continued

Elevation System - Breakdown - Continued

POS.	PART NUMBER	DESCRIPTION	QTY. REQD.	NOTES
37	1600-600005-00	MOUNTING PLATE I	1	
38	CK10-510004-00	DRAG HEAD I	2	
39	1120-500006-00	MICRO-SWITCH	4	
40	1600-520006-10	SWITCH HARNESS	1	
41	0000-000617-00	SCREW M4×20	6	
42	1600-600001-00	DRAG BRACKET	1	
43	1600-600015-A0	BRACKET I	1	
44	1600-520012-1A	SWITCH WIRE HARNESS DOWN	1	
45	1600-600006-A0	MOUNTING PLATE I	2	
46	0000-001029-00	SCREW M4×8	4	
47	0000-000122-00	LOCK WASHER Ø4	4	
48	0000-000702-00	FLAT WASHER Ø4	4	

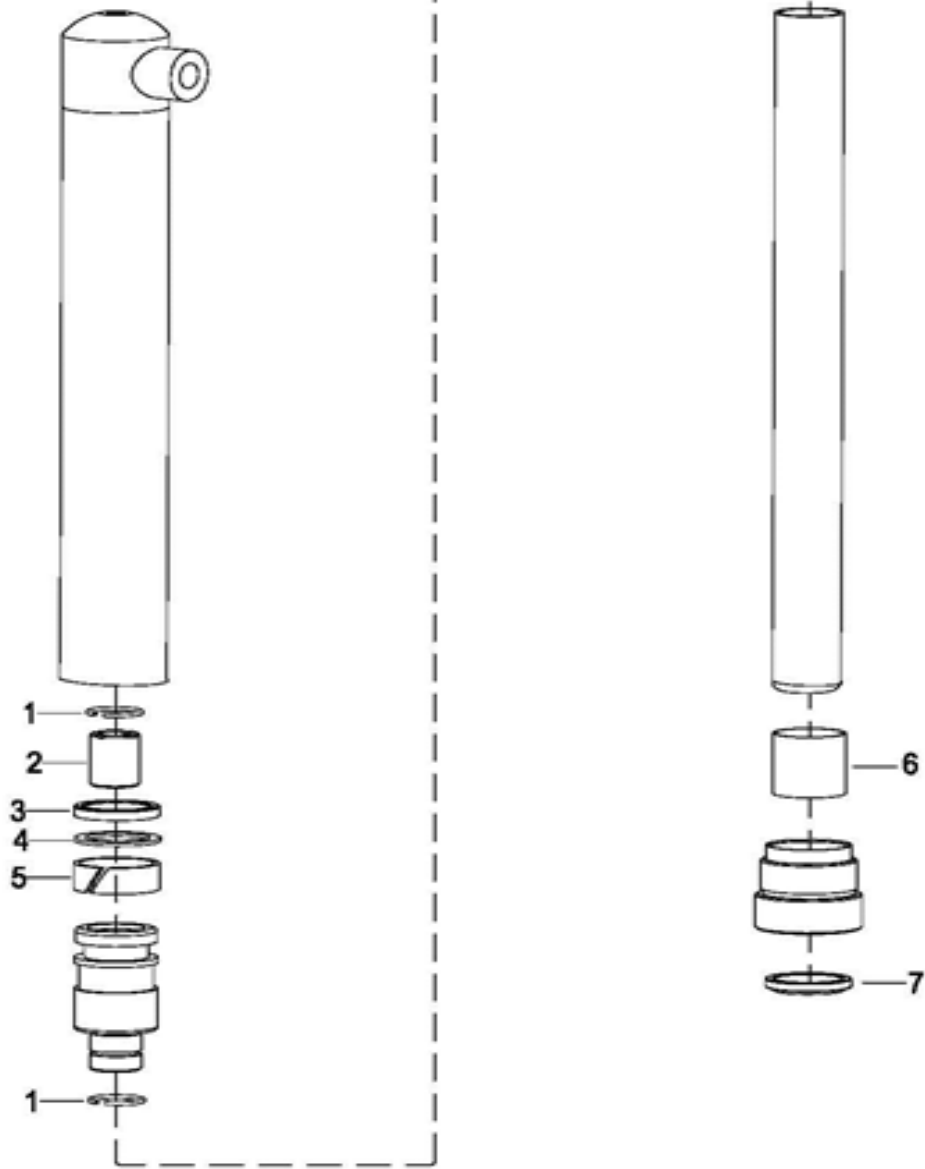

EC_0015

Figure 11-15 Lift Cylinder

Lift Cylinder

POS.	PART NUMBER	DESCRIPTION	QTY. REQD.	NOTES
--	1600-411000-00	LIFT CYLINDER	1	
KIT	1600-2BG2	SEAL KIT FOR CYLINDER	1	Includes pos. # 4 & 11
1	2125-416000-00	SNAP RING 26.5×2.2	1	
2	CK10-414000-30	BUFFER SLEEVE	1	
3	1600-411001-00	RING 30×40×6	1	
4	1600-411002-00	SEAL 30×40×2	1	
5	1600-411003-00	SUPPORT CENTRAL 40×35×15	1	
6	1600-411004-00	BEARING 36×32×35	1	
7	1600-411005-00	DUST SEAL 32×40×5/6.5	1	

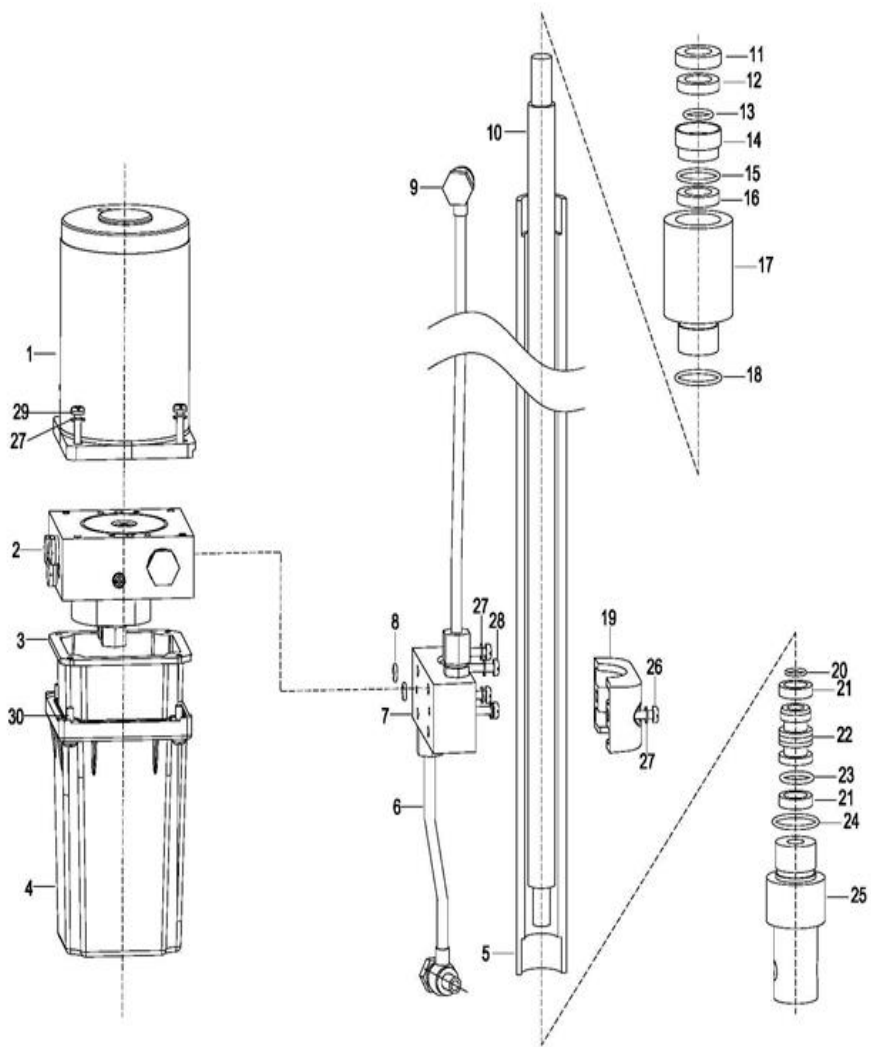

EC_0019

Figure 11-16 Lift Cylinder Assembly - Tray

Lift Cylinder Assembly - Tray

POS.	PART NUMBER	DESCRIPTION	QTY. REQD.	NOTES
--	1600-660000-0A	LIFT CYLINDER ASSEMBLY - TRAY	1	This is a complete assembly.
1	1600-660001-00	MOTOR	1	
2	1600-660002-00	GEAR PUMP	1	
3	1600-660003-00	OIL SAC	1	
4	1600-660004-00	SHIELD	1	
5	1600-660005-00	CYLINDER BLOCK	1	
6	1600-660006-00	LOWER TUBING ASSEMBLY	1	
7	1600-660007-00	MOUNTING SEAT	1	
8	1600-660008-00	O-RING	2	
9	1600-660009-00	UPPER TUBING ASSEMBLY	1	
10	1600-660010-00	ROD	1	
11	1600-660011-00	SNAP RING M28×1	1	
12	1600-660012-00	DUST RING	1	
13	1600-660013-00	SEAL Ø19×1.9	1	
14	1600-660014-00	COPPER SLEEVE	1	
15	1600-660015-00	SEAL Ø24×2.4	1	
16	1600-660016-00	OIL SEAL DZ24×16×5	1	
17	1600-660017-00	COVER	1	
18	1600-660018-00	SEA Ø24×2	1	
19	1600-660019-00	HOOP	1	
20	1600-660020-00	ROD SEAL RING Ø12×1.5	1	
21	1600-660021-00	OIL SEAL DZ20×14×5	2	
22	1600-660022-00	PISTON	1	
23	1600-660023-00	ROD SEAL RING Ø9×1.9	1	
24	1600-660024-00	BASE SEAL RING Ø24×2	1	
25	1600-660025-00	BASE	1	
26	1600-660026-00	SCREW M5×14	2	
27	1600-660027-00	LOCK WASHER Ø5	10	
28	1600-660028-00	SCREW M5×12	4	
29	1600-660029-00	SCREW M5×16	4	
30	1600-660030-00	SCREW M4×16	4	
31	1600-2BG1	SEAL KIT FOR CYLINDER	1	Incl. pos. # 8,12,13,15,18,20,23,24

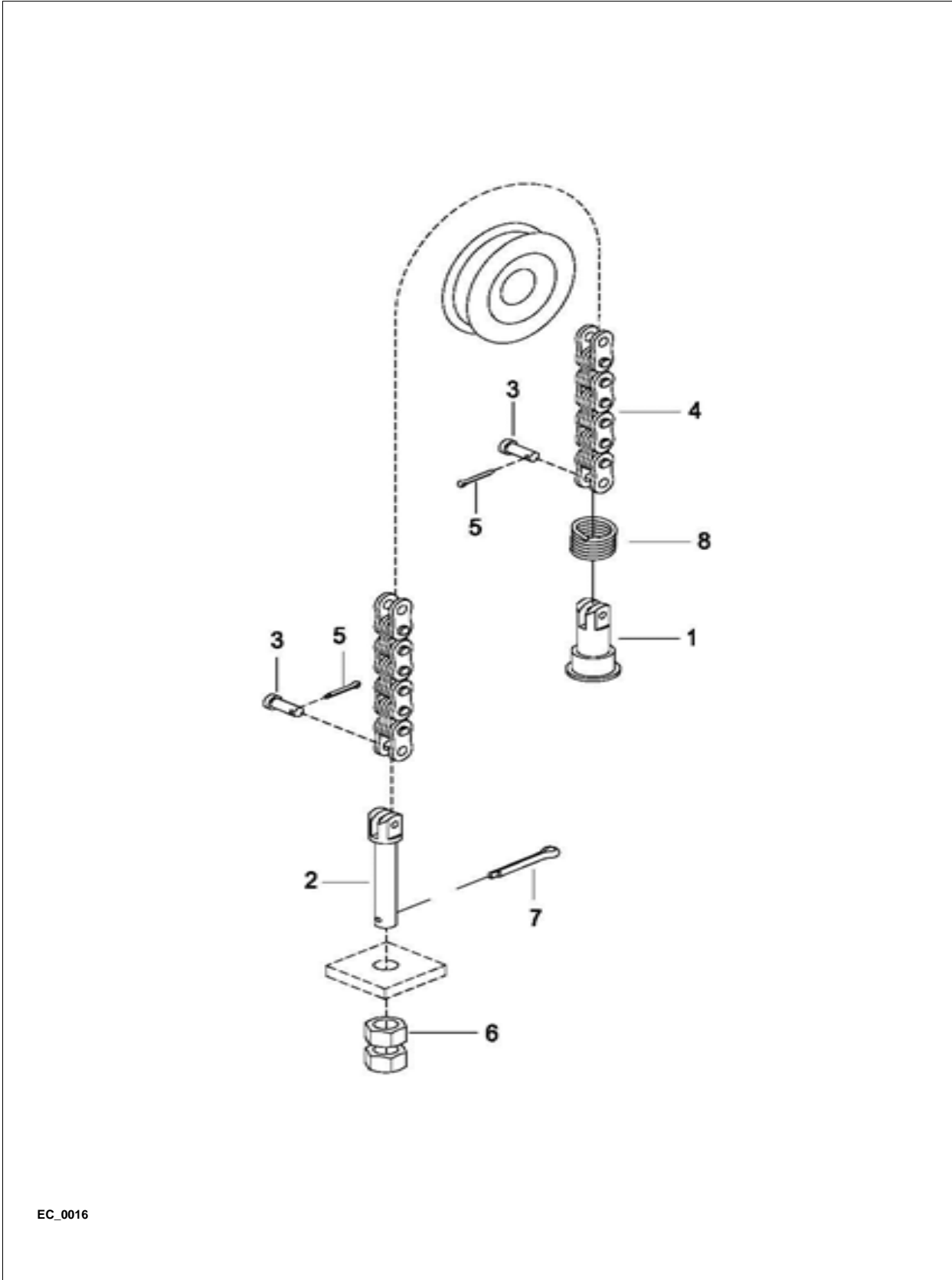

EC_0016

Figure 11-17 Chain Assembly

Chain Assembly

POS.	PART NUMBER	DESCRIPTION	QTY. REQD.	NOTES
1	1600-600302-A0	CHAIN JOINT II	1	
2	1600-600301-A0	CHAIN JOINT I	1	
3	1600-600304-A0	SHAFT	2	
4	1600-600303-A0	CHAIN ~	1	
4	1600-600403-A0	CHAIN II	1	
5	307001000023	COTTER 1.6X20	2	
6	0000-000553-00	NUT M10	2	
7	0000-000296-00	COTTER PIN Ø2×20	1	
8	1600-600305-A0	SPRING	1	

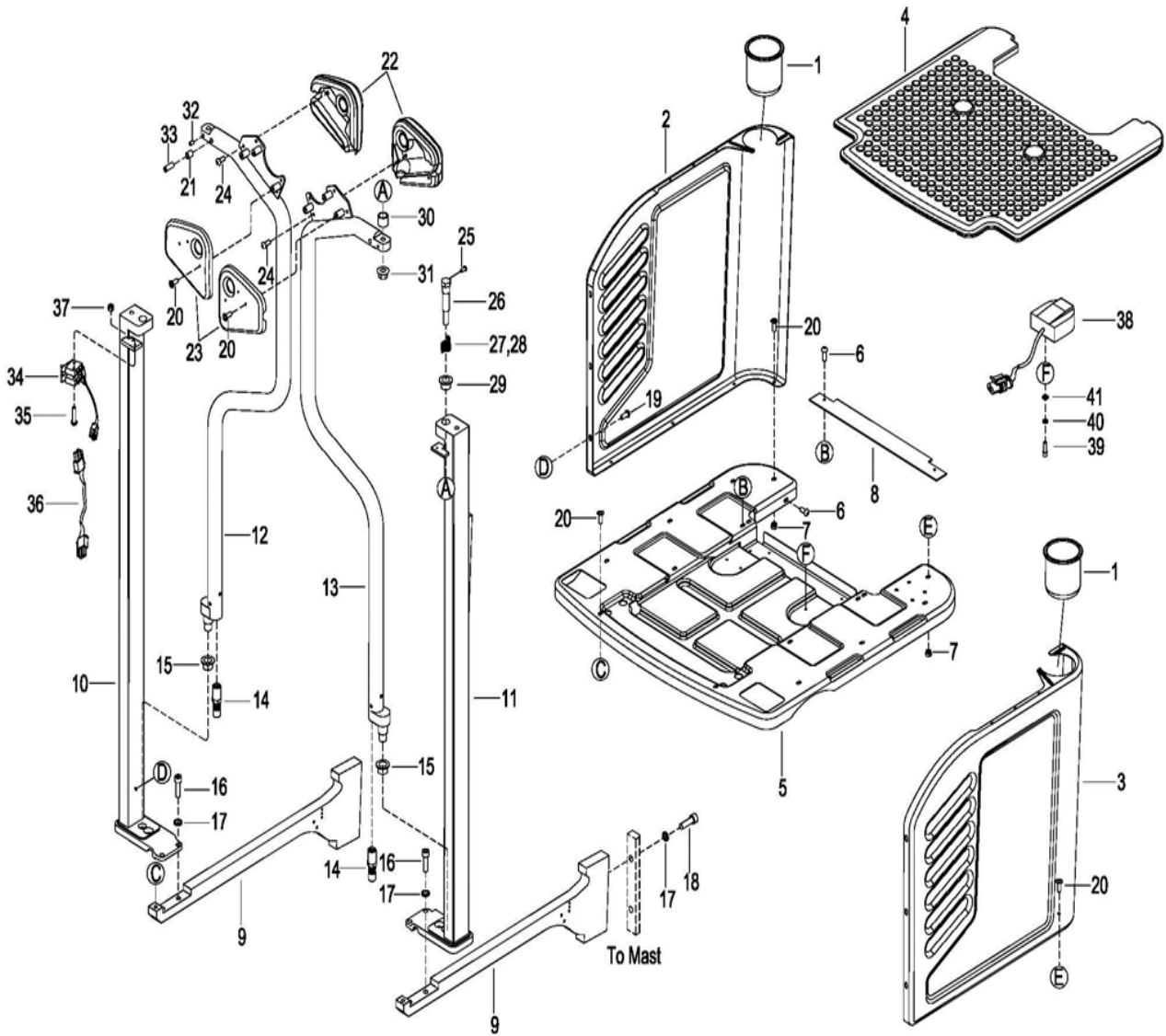

EC_0017

Figure 11-18 Operator Platform

Operator Platform

POS.	PART NUMBER	DESCRIPTION	QTY. REQD.	NOTES
1	1600-700005-A0	CUP HOLDER	2	
2	1600-710400-A0-01	LEFT GUARDRAIL	1	Red
2a	1600-710400-A0-02	LEFT GUARDRAIL	1	Yellow
3	1600-710301-A0-01	RIGHT COVER	1	Red
3a	1600-710301-A0-02	RIGHT COVER	1	Yellow
4	1600-700004-A0	RUBBER FLOOR	1	
5	1600-700002-A0	FLOOR	1	
6	0000-000021-00	SCREW M6X12	18	
7	3030-060000-02	NUT M6	6	
8	1600-700003-A0	WIRE COVER	1	
9	1600-710001-A0	SHORE	2	
10	1600-710100-A0	DOOR COLUMN LEFT	1	
11	1600-710200-A0	DOOR COLUMN RIGHT	1	
12	1600-704000-0B	LEFT DOOR	1	
13	1600-702000-0B	RIGHT DOOR	1	
14	1600-703000-00	PIN MECHANISM	2	
15	2028-019000-04	SLEEVE 1612	2	
16	0000-000322-00	SCREW M8X25	4	
17	0000-000159-00	LOCK WASHER Ø8	4	
18	0000-000026-00	SCREW M8X30	4	
19	2028-000000-18	SCREW M6X20	6	
20	2028-000000-17	SCREW M6X12	14	
21	1600-700012-00	BUMPER	2	
22	1600-704001-0B	DOOR HANDLE	1	
23	1600-704002-0B	BACK COVER	1	
24	0000-000119-00	SCREW M5X12	8	
25	0000-000701-00	SCREW M4X10	4	
26	1600-700002-00	AXIS	2	
27	1600-700003-00	SPRING LEFT	1	
28	1600-700010-00	SPRING RIGHT	1	
29	202801900044	SLEEVE	2	
30	1600-700005-00	BUSHING	2	
31	303030000001	NUT M10	2	
32	0000-001521-00	SCREW M5X10	4	
33	302006000007	SCREW M8X20	2	
34	1600-520009-0A	DOOR SWITCH HARNESS	2	
35	302004000001	SCREW M2X12	4	

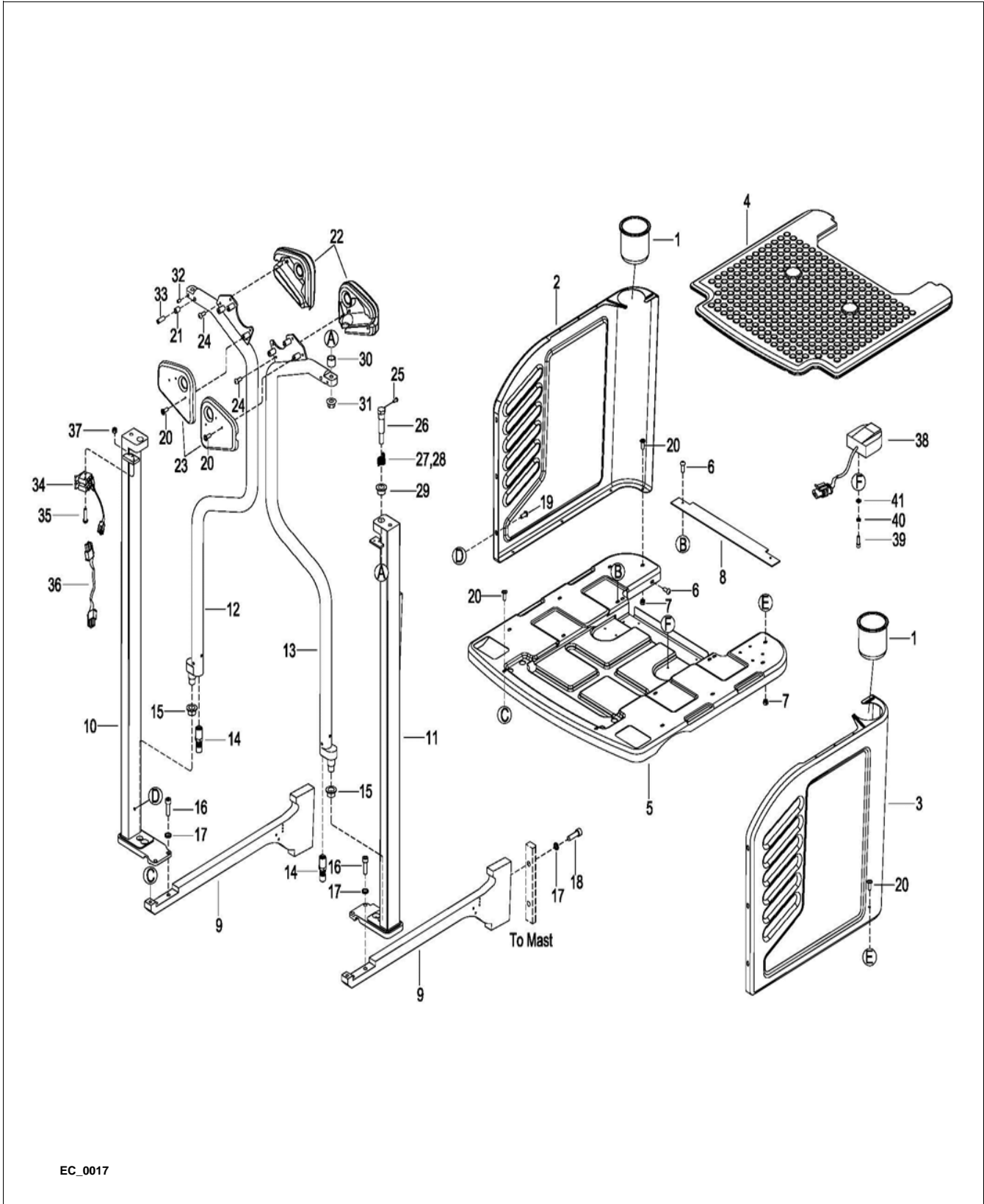

EC_0017

Figure 11-18 Operator Platform - Continued

Operator Platform - Continued

POS.	PART NUMBER	DESCRIPTION	QTY. REQD.	NOTES
36	1600-520010-00	CONNECTING LINE	2	
37	3030-220000-06	NUT M2	4	
38	1600-520015-00	BRAKE SWITCH	1	
39	0000-000028-00	SCREW M4×10	2	
40	0000-000122-00	LOCK WASHER Ø4	2	
41	0000-000702-00	FLAT WASHER Ø4	2	
36	1600-520010-00	CONNECTING LINE	2	
37	3030-220000-06	NUT M2	4	
38	1600-520015-00	BRAKE SWITCH	1	
39	0000-000028-00	SCREW M4×10	2	
40	0000-000122-00	LOCK WASHER Ø4	2	
41	0000-000702-00	FLAT WASHER Ø4	2	

BLUE GIANT[®]
BLUE GIANT EQUIPMENT CORPORATION

Corporate 410 Admiral Blvd
Mississauga ON L5T 2N6
t 905.457.3900 f 905.457.2313

USA 6350 Burnt Poplar Rd
Greensboro, NC 27409
www.bluegiant.com